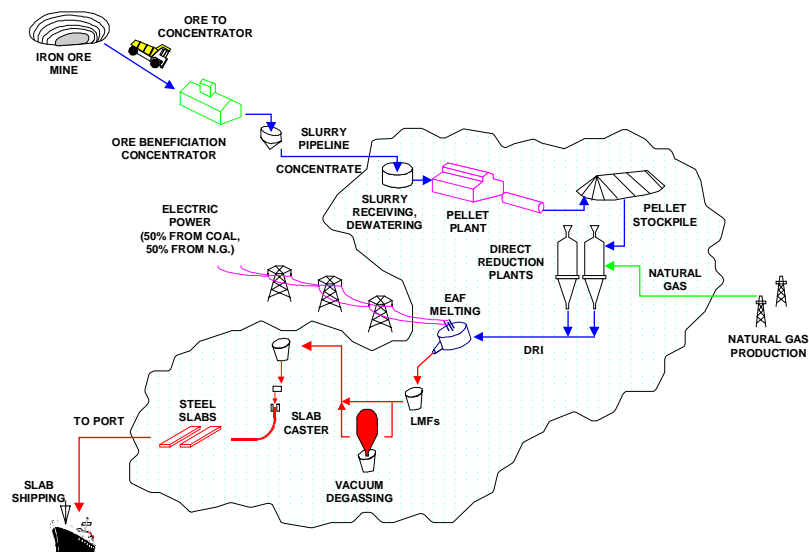




# Ironmaking Process Alternatives Screening Study

## Volume I: Summary Report



October 2000

LG Job No. 010529.01

**LOCKWOOD GREENE**  
MECHANICAL SERVICES

**LOCKWOOD GREENE**

---

# Contents

## **Volume I: Ironmaking Alternative Study**

Executive Summary .....	1
Study Scope and Methodology.....	2
Ironmaking Process Discussion and Grouping .....	3
Discussion of Ranking Analysis .....	4
Summary and Conclusions .....	5

---

# Report Outline

## Section 1: Executive Summary

- 1-1: General Discussion
- 1-2: Summary Conclusions

## Section 2: Study Scope and Methodology

- 2-1: Study Scope
  - 2-1.1 Introduction
  - 2-1.2 Scope/Objective
- 2-2: Methodology and Approach
  - 2-2.1: Introduction to the MetSim Process Simulator
  - 2-2.2: Simulation Models of Ironmaking Processes
  - 2-2.3: Spreadsheet Mass Balances of Process Components
  - 2-2.4: Spreadsheet Mass Balances of Ironmaking Processes
- 2-3: Base Process Location
  - 2-3.1: Base Location Assumptions
  - 2-3.2: Location Sensitivities
- 2-4: Process Capital (CAPEX) and Operating Cost (OPEX) Estimates
  - 2-4.1 Process Capital Costs (CAPEX)
  - 2-4.2 Process Operating Costs (OPEX)

---

## **Section 3: Ironmaking Process Discussion and Grouping**

- 3-1:** Processes Considered and Initial Screening
  - 3-1.1** Processes Considered in Initial Screening
  - 3-1.2** Process Scenarios Selected
  
- 3-2:** Process Descriptions
  - 3-2.1** Shaft Furnace Processes
  - 3-2.2** Rotary Kiln
  - 3-2.3** Rotary Hearth
  - 3-2.4** Fluidized Bed
  - 3-2.5** Other (Reactor, etc.)
  
- 3-3:** Process Groupings
  - 3-3.1** Grouping By Product Type
  - 3-3.2** Grouping By Stage of Commercial Development
  - 3-3.3** Grouping By Iron Unit Feed Material
  - 3-3.4** Grouping By Primary Reductant Type
  - 3-3.5** Grouping By Reduction Process Type
  - 3-3.6** Grouping By Target Nominal Size of Reduction Unit/Train

## **Section 4: Discussion of Ranking Analysis**

- 4-1:** Ranking Variables Considered
  
- 4-2:** Sorting and Ranking By Capital Cost Estimates (Through L.S. Production)
  
- 4-3:** Sorting and Ranking By Operating Cost (OPEX) Estimates Through Liquid Steel Production

- 
- 4-4:           Sorting and Ranking By Operating Cost (OPEX) Estimates Through Iron Unit Production
  - 4-5:           Sorting and Ranking By Simple Internal Rate of Return (I.R.R.)
  - 4-6:           Sorting and Rankings By Total Electrical Power Consumptions
  - 4-7:           Sorting and Ranking By Cumulative Process Greenhouse Gas (As CO<sub>2</sub> only) Emissions
  
  - 4-8:           Sorting and Ranking By Total Cumulative (Including Electrical Power Generation Contribution) Greenhouse Gas Emissions
  
  - 4-9:           Weighted Ranking Summary (All Variables)

## **Section 5: Summary and Conclusions**

- 5-1:           Conclusions From Sorts
  - 5-1.1   Sorting on Capital Cost Estimates
  - 5-1.2   Sorting on Operating Costs for Liquid Steel Production
  - 5-1.3   Sorting on Operating Costs for Iron Unit Production
  - 5-1.4   Sorting on Simple Internal Rate of Return (I.R.R.)
  - 5-1.5   Sorting on Total Electric Power Consumption
  - 5-1.6   Sorting on Cumulative Process (only) Greenhouse Gas (as CO<sub>2</sub>) Emissions
  - 5-1.7   Sorting on Total Cumulative Greenhouse Gas (as CO<sub>2</sub>) Emissions (Including Electrical Power Generation Contribution)

- 
- 5-2:** Conclusions From Ranking Sorts
    - 5-2.1** Ranking Sort on Economic Variables (1-4)
    - 5-2.2** Ranking Sort on Energy and Environmental Variables (5-7)
    - 5-2.3** Ranking Sort on All Variables (1-7)
  
  - 5-3:** General Conclusions From Sorting and Ranking Sums

---

## Section 1: Executive Summary

### **1-1: General Discussion**

Iron in the United States is largely produced from iron ore mined in the United States or imported from Canada or South America. The iron ore is typically smelted in Blast Furnaces that use primarily iron ore, iron concentrate pellets metallurgical coke, limestone and lime as the raw materials. Under current operating scenarios, the iron produced from these Blast Furnaces is relatively inexpensive as compared to current alternative iron sources, e.g. direct iron reduction, imported pig iron, etc.

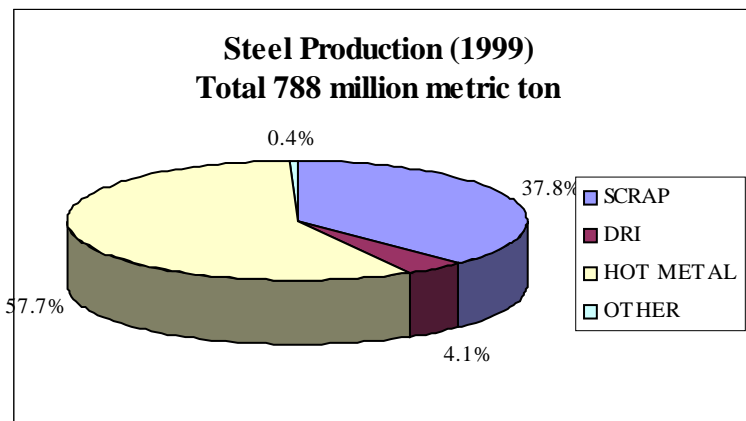
The primary problem the Blast Furnace Ironmaking approach is that many of these Blast furnaces are relatively small, as compared to the newer, larger Blast Furnaces; thus are relatively costly and inefficient to operate. An additional problem is also that supplies of high-grade metallurgical grade coke are becoming increasingly in short supply and costs are also increasing. In part this is due to the short supply and costs of high-grade metallurgical coals, but also this is due to the increasing necessity for environmental controls for coke production.

After year 2003 new regulations for coke product environmental requirement will likely be promulgated. It is likely that this also will either increase the cost of high-quality coke production or will reduce the available domestic U.S. supply. Therefore, iron production in the United States utilizing the current, predominant Blast Furnace process will be more costly and would likely be curtailed due to a coke shortage.

Therefore, there is a significant need to develop or extend the economic viability of Alternate Ironmaking Processes to at least partially replace current and declining blast furnace iron sources and to provide incentives for new capacity expansion.

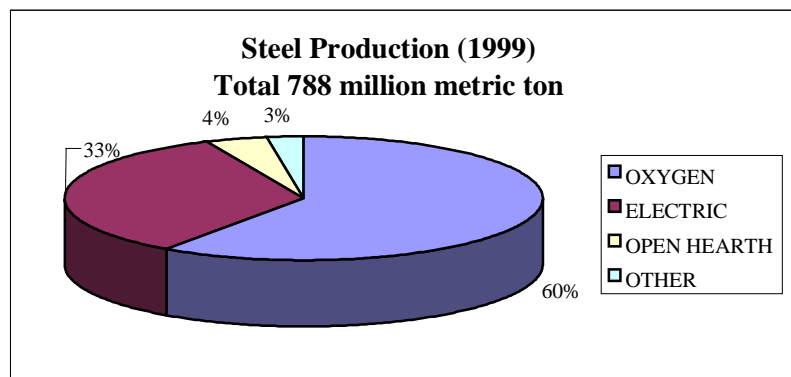
In the chart below, Steelmaking Feed Materials (1999) are denoted. It can be seen that Hot Metal (primarily from Blast Furnaces) constitutes approximately 58% of the Iron Unit Feed to Steelmaking. Recycled Steel Scrap provides about 38% of the feed and Direct Reduced Iron (DRI) was only 4% of the raw materials for Steelmaking.

### STEELMAKING FEED MATERIALS



The chart, Steelmaking by Process Type, summarizes the predominant Steelmaking processes used in the world. The majority of the Steel (60%) is produced by Oxygen reactor processes (i.e. BOF, QBOP, etc.). Following behind is the Electric Arc Process (EAF) with 33% and a residual quantity (4%) by the open hearth process.

### STEELMAKING BY PROCESS TYPE

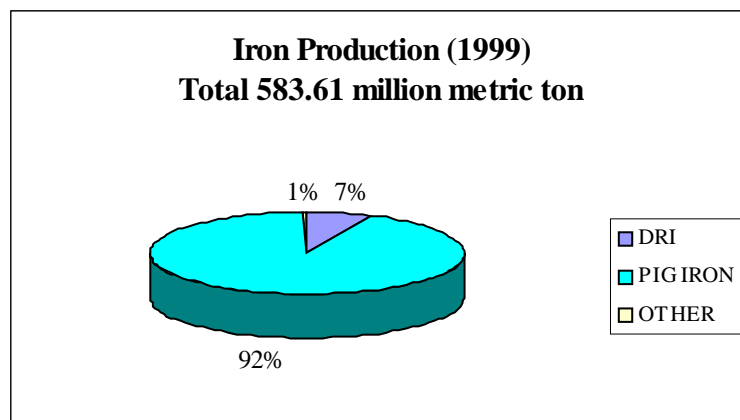




---

Based on a total new Iron Unit Production, the overwhelming percentage (92%) is either Blast Furnace Hot Metal or pig iron. A minority percentage (7%) is from Direct Reduction Processes and the balance is other iron sources.

## IRON UNIT PRODUCTION



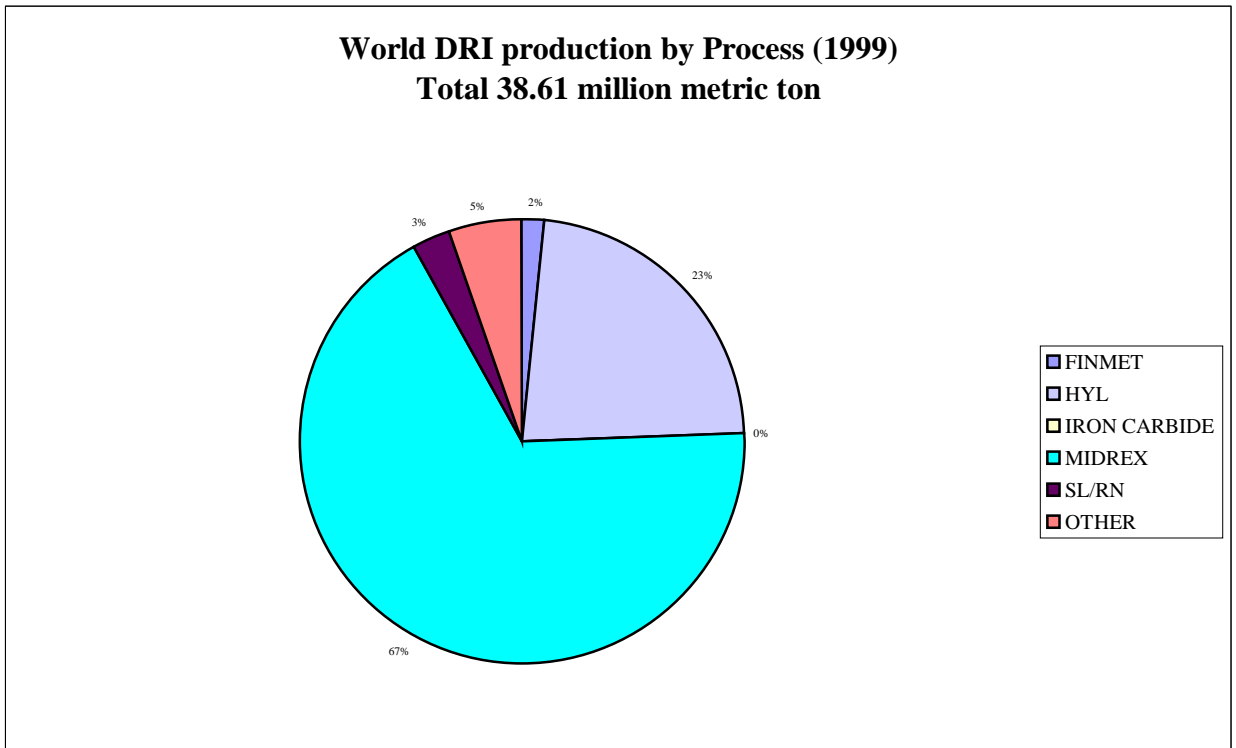
Of the Alternative Direct Iron Reduction Processes, 67% of the DRI is produced by the Midrex Shaft Furnace DRI processes. The second-most production of DRI (23%) is by the HYLSA processes. The balance is split between SL/RN (3%), Finmet (2%) and Other (predominately Corex at 5%). It is significant that the Shaft Furnace processes produce nearly 90% of the total Alternative Iron Units.

Although there are a number of Alternative Ironmaking Processes in the startup phase or development for commercial operation (e.g. Circored, Iron Carbide, the Rotary Hearth Processes, Tecnored, etc.), non as yet challenge the Shaft Furnace Processes. One of the constraints on these Shaft Furnace processes is that they require either high-grade lump ore or pellets as their iron unit raw material feed. Costs for such feeds are going up and there are limitations in supply.

The fine ore processes appear to present one possible avenue for economic Alternative Ironmaking Process development. The lower costs of the fine ores make the fluidized bed processes that utilize them potentially-attractive targets for development. Processes where fine ore is combined with low-cost coal reduction (e.g. Tecnored, the Rotary Hearth Processes,

etc.) also are potential Alternative Ironmaking processes that would warrant further development.

## DRI PRODUCTION BY PROCESS TYPE



---

## 1-2: Summary Conclusions

The primary conclusions of this comparative Study of Alternative Ironmaking Process scenarios are:

- The processes with the best combined economics (CAPEX and OPEX impacts in the I.R.R. calculation) can be grouped into those Fine Ore based processes with no scrap charge and those producing Hot Metal for charge to the EAF.
- A pronounced sensitivity to Steel Scrap Cost was felt less by the Hot Metal Processes and the Fine Ore Processes that typically do not utilize much purchased scrap.
- In terms of evolving processes, the Tecnored Process (and in particular, the lower-operating cost process with integral co-generation of electrical power) was in the most favorable groupings at all scrap cost sensitivities.
- It should be noted also that the Conventional Blast Furnace process utilizing Non-Recovery coke (from a continuous coking process with integral co-generation of electrical power) and the lower-capital cost Mini Blast Furnace also showed favorable Relative Economics for the low and median Scrap Cost sensitivities.
- The lower-cost, more efficient MauMee Rotary Hearth Process that uses a Briquetted Iron Unit Feed (instead of a dried or indurated iron ore pellet) also was in the most favorable process groupings.

Those processes with lower-cost raw materials (i.e. fine ore and/or non-metallurgical coal as the reductant) had favorable combined economics. In addition, the hot metal processes (in part due to the sensible heat impacts in the EAF and due to their inherently lower costs) also had favorable combined economics.

As a group, the Hot Metal processes had lower Total Cumulative Electrical Power Consumption, lower Process Emissions and lower Total Emissions (including Electrical Power generation). These were reflected also in the Ranking Sum Analysis. The exception was the Shaft Furnace DRI process (Midrex) that was in the lower group for the environmental-related variables.

---

As an ancillary conclusion of this study, there is significant potential to extend the viable economic life of the existing Blast Furnace Process infrastructure (and perhaps future Mini Blast Furnace) by further developing and exploiting the evolving continuous Non-Recovery Coking processes. Lockwood Greene is aware of several such processes that are being developed. Some have had some pilot plant-scale production and application testing, others are in the planning stages for pilot demonstration.

What these processes have in common are:

- All do not have the environmental burden of producing and disposing of the noxious chemical by-products of the coking process.
- All are energy efficient (mostly autogenous) and produce waste heat that could be utilized directly or to co-generate electrical power.
- Some utilize low-cost alternate and residual carbon sources as well as low-rank coals to produce a formed-coke product. The increasing costs and shortage of high-grade coking coal is mitigated by the use of the plentiful, low-cost alternatives.
- Most of all, due to the complete combustion of the coking by-products and to integral pollution and emission controls, these non-recovery coking processes as a group are much more environmentally acceptable than conventional coking processes.

In this Alternative Ironmaking Process Study, the differences in total emissions between a conventional, co-product coke Blast Furnace and one utilizing the continuous non-recovery coking process (coke substitution only) for these two, otherwise identical, cases indicated that there was approximately a 7% lower total emissions from the Non-Recovery Coke/Blast Furnace process relative to the Conventional Co-Product Coke/Blasé Furnace.

With the inclusion of co-generation that is an integral part of the Continuous Non-Recovery Coke process, there was a 22% reduction in emissions due to total cumulative electrical power related emissions. This kind of environmental difference may provide incentives or constraints to utilize the lower-emitting technologies.

---

The evolution of a lower-cost, energy-efficient and environmentally-friendly coke producing process that can utilize common carbon recycle and waste materials as well as abundant low-rank coal as the primary carbon sources will have a significant impact on production of Iron Units.

This alternative may extend the life of the existing Blast Furnace infrastructure and it may present significant options for the adoption of the more-flexible and lower capital cost (per iron unit capacity) Mini Blast Furnace or developing processes such as Tecnoled.

---

## Section 2: Study Scope and Approach

### **2-1: Study Scope**

#### **2-1.1: Introduction:**

Iron in the United States is largely produced from iron ore mined in the United States or imported from Canada or South America. The iron ore is typically smelted in Blast Furnaces that use primarily iron ore, metallurgical coke, limestone and lime as the raw materials. Some alternate fuel sources, small percentages supplied by direct coal or natural gas injection, are also utilized in place of the coke. Under current operating scenarios, the iron produced from these Blast Furnaces is relatively inexpensive as compared to current alternative iron sources, e.g. direct iron reduction, imported pig iron, etc.

The primary problem the Blast Furnace Ironmaking approach is that many of these Blast furnaces are relatively small, as compared to the newer, larger Blast Furnaces; thus are relatively costly and inefficient to operate. An additional problem is also that supplies of high-grade metallurgical grade coke are becoming increasingly in short supply and costs are also increasing. In part this is due to the short supply and costs of high-grade metallurgical coals, but also this is due to the increasing necessity for environmental controls for coke production.

Proposed and mandated environmental regulations for coke production will significantly increase the shortfall of domestic coke production during the interim extension period from 1998-2003 during which new coke production technologies and environmental control strategies are to be developed. After year 2003 new regulations for coke product environmental requirement will likely be promulgated. It is likely that this also will either increase the cost of high-quality coke production or will reduce the available domestic U.S. supply. Therefore, iron production in the United States utilizing the current, predominant Blast Furnace process will be more costly and would likely be curtailed due to a coke shortage.

Utilization of higher percentages of imported coke in the existing Blast Furnace infrastructure will not solve the problems of short supply

---

completely since the typically inferior quality of these sources result in less Blast Furnace productivity and higher operating and maintenance costs. This imported coke will likely also increase in cost and become unavailable as the market demands increase.

There may be restrictions or tariffs on the use of such imported coke if it is produced under conditions such that significant environmental emissions result. As is the current case, almost all of the offshore sources of imported coke (and the domestic sources with few exceptions) do not meet current or proposed U.S. environmental standards for emissions. As a consequence, this may not be a significant viable source of supply after year 2003.

Therefore, there is a significant need to develop or extend the economic viability of Alternate Ironmaking Processes to at least partially replace current and declining blast furnace iron sources and to provide incentives for new capacity expansion.

**2-1.2:** Scope/Objective:

A study was initiated to compare a number of Alternative Ironmaking Processes by Lockwood Greene Engineers in January, 2000 based on the following Scope-of-Work. This work was done in conjunction with Lockwood Greene Technologies who contracted for the study to Lockheed Martin Energy Research Corporation, the operating agency for the U. S. Department of Energy at the Oak Ridge Laboratories facility.

The objective of the study was to evaluate a number of alternative proven and promising ironmaking processes that will feed iron units to current and future steelmaking processes. An initial review of available technologies was made with a view toward grouping for evaluation similar or derivative processes. These groupings plus initial energy and mass balance considerations allowed a preliminary screening, selection and final groupings of the promising process alternatives.

Reasonably accurate and relatively precise methodologies were utilized to develop quantitative measurements of process capital and operating costs, energy consumption and environmental emissions. A standard scenario of the requirements to produce 1.0 MM annual metric tons (tonnes) of refined liquid steel (by an Electric Arc Furnace and Ladle Refining Furnace,

---

EAF/LRF scenario) was utilized to normalize the basis of comparison for all ironmaking technologies.

The true objective of the study was to define those alternative ironmaking processes that were lowest in costs while remaining environmentally friendly.

## **2-2: Methodology and Approach**

Each process considered were defined and specified, where possible, to the same level of confidence. In-house Lockwood Greene Engineers detailed process flow diagrams; spreadsheet mass balance models and process simulation models were utilized as the basis for the comparisons. For each process, the beginning point of evaluation was the primary iron unit source and the final point of evaluation was the refined liquid steel product. In addition, specific Process Vendor inputs to define the specifics of the heat and mass balances and the capital and operating costs were also utilized.

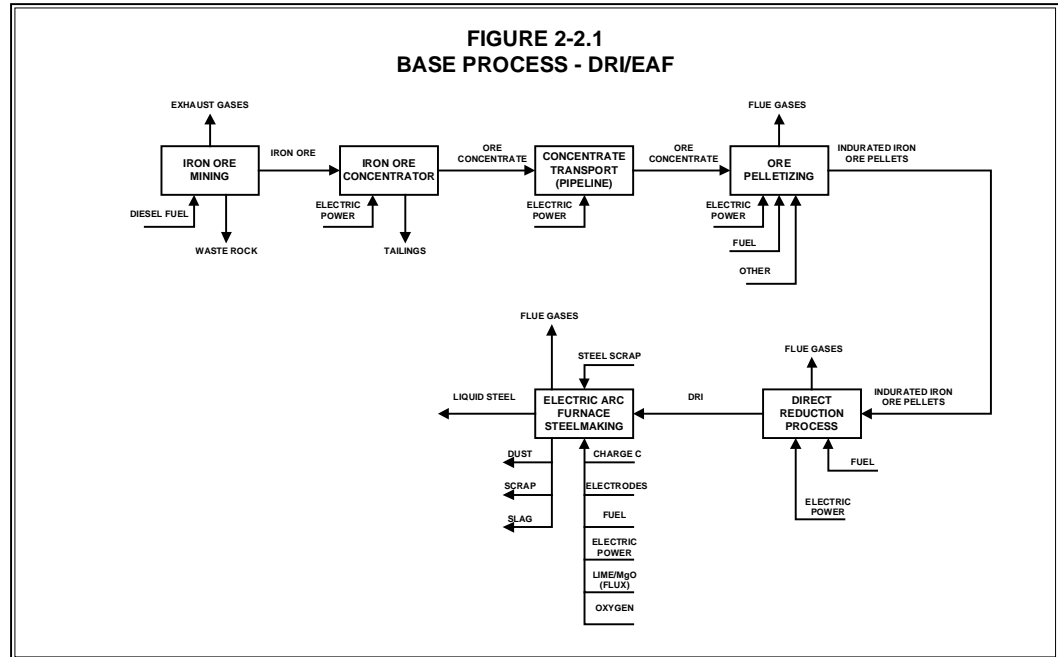
The primary reason for this approach was to have a relative comparison of the cumulative energy consumptions (as electric power, fuel or other consumables) and to provide a basis for the cumulative emission of carbon waste gases. For purposes of comparison, all carbon gases leaving the process were taken to be as CO<sub>2</sub>.

The overall mass and component balances for each of the sequence and train of various preparation processes and unit operations preceding the ironmaking and steelmaking processes defines the specific sizing and cost factor requirements for the preceding processes. In addition, the quantities of raw materials, fuels and other commodities were defined for operating cost development. The relationships for the primary raw materials themselves are also built up from their various components also.

Each component is defined and represented by a rigorous working spreadsheet heat and material balance model. The combination of the various components results in a similar built-up spreadsheet model for the primary raw materials. Extending that further, these raw materials production models are combined and strung together to form the unit process models.



For example, the steps to produce an iron ore pellet are illustrated in Figure 2-2.1 below:



Preceding the production of iron ore pellets are the unit processes of:

- Iron Ore Mining
- Iron Ore Concentrating
- Transport of Concentrate (e.g. slurry pipeline)
- Then Pelletizing

Similarly, the iron ore pellets are the primary raw material for the Direct Reduction Process to produce Direct Reduced Iron which, in turn, is the primary raw material for the Electric Arc Steelmaking Process to produce refined liquid steel. The detailed component Block Flow Diagrams (BFDs) for the major raw materials for the Ironmaking Processes (e.g. electrical power, tonnage oxygen, burnt lime, non-recovery and co-product coke, etc.) are presented in the Appendix A-3. Also presented in Appendix A-3 are BFDs for the major Ironmaking Processes showing the similar methodology

---

for the built-up spreadsheet balance models utilized as the basis for definition and comparison in this study.

### 2-2.1: Introduction to the MetSim Process Simulator

The basis for analysis of all chemical and metallurgical processes is the mass and energy balance. Plant design, capital costs, operating costs, and technical evaluations are all dependent on such calculations. MetSim is a general-purpose process simulation system designed to assist the engineer in performing mass and energy balances of complex processes. MetSim uses an assortment of computational methods to effect an optimum combination of complexity, user time, and computer resource usage.

MetSim can perform mass and energy balance calculations for:

- Process feasibility studies
- Alternative flowsheet evaluations
- Pilot plant data evaluation
- Full scale plant design calculations
- Operating plant improvement studies
- Actual plant operations and control.

MetSim performs mass and energy balances for chemical/metallurgical processes using the sequential modular approach. A major advantage of this approach is that intermediate results may be obtained from any stage of the process in an intelligible form. In conformance with the sequential modular approach, MetSim comprises modules containing subsets of equations describing the design specifications and performance characteristics for each process step. The system solves the equation subset for each module, allowing for an individual analysis of each unit operation in the flowsheet.

Given data on design variables and input stream composition, each module calculates all of the output stream variables that can then be used as input stream values for the next process step. The modules access data on all independent stream variables from the data arrays contained within the APL (the computer language used for writing MetSim code) global workspace. Additional input data required to solve the equations in each module are requested by the program and are stored as global variables.

---

The user may supply actual data obtained from operating or pilot plants, from similar processes, or from estimates supplied by the engineer.

Unlike most other process simulators, MetSim eliminates the need for user involvement in recycle stream tearing. MetSim employs a technique whereby the user is required only to provide initial estimates of the recycle stream content of critical process streams.

For process adjustment and control, MetSim uses feedforward and feedback controllers. Because of similarity between the dynamic behavior of MetSim control and that of process control in operating plants, unstable control strategies can often be located during the modeling stage, avoiding costly field modification and retrofit.

The successful application of the MetSim system of programs involves more than simply entering fixed data on standardized input sheets. Due to wide variation in chemical and mineral processing techniques, available data, process criteria, and output data requirements, the development of process models is as much an art as it is a science. It involves familiarity with mathematical modeling, numerical analysis and process control. The user must be familiar with process engineering mass and energy balance calculations. Thus it supplements, not replaces, sound engineering practices and judgment.

---

## 2-2.2: Simulation Models of Ironmaking Processes

A primary component in developing and defining the combined component Spreadsheet Heat and Mass balance models of the various Ironmaking Processes are the MetSim Simulation Models of the Ironmaking Processes. As discussed earlier, the balances for the various Ironmaking Processes are normalized using the basis of production as being 1.0 MM tonnes of Refined Liquid Steel (RLS) per year as the common denominator. In all cases considered, the RLS production route utilized the various forms of iron produced (i.e. liquid hot metal, cold pig iron, direct reduced iron, etc.) by the various Ironmaking Process as the primary iron source to an appropriate EAF/LRF operation.

The commercially-available MetSim process simulation software system (Proware, Phoenix, AZ) as described in Section 2.2.1 was utilized to develop the rigorous simulation models of most of the various Ironmaking Processes. MetSim provides the system by which the fundamental chemical reactions and equilibria in the Gas, Liquid and Solid phases of Ironmaking can be simulated under a simultaneous equilibrium operating conditions. However, the model developer must define these fundamental chemical reactions, the chemical yields or extent of reaction, the components for the various phases and organize the model to simulate the entire flowsheet of the Ironmaking Process.

Such a process simulation model (as opposed to a simple spreadsheet balance model) will actually predict the behavior and performance of the entire process. The entire flowsheet itself including: the process, the reducing gas production and recirculating streams, the cooling water requirements, and the off-gases or emissions are modeled.

Controls and process control loops are provided (as in the actual operating process) to allow the modeler to specify and constrain the process performance and product requirements. As changes are made in the assumptions for raw materials, process inputs or for operating conditions are made by the modeler, the prediction of the variations of the outcomes of the simulated process can provide sensitivities of production, yield, product quality, etc.

---

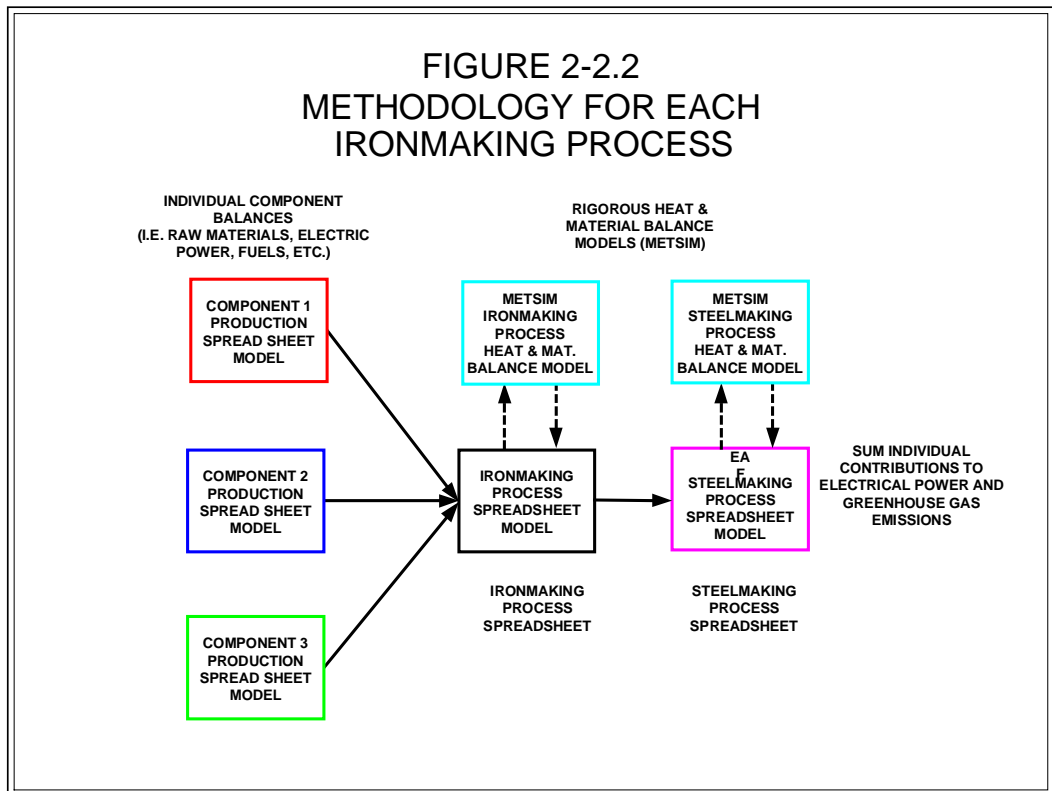
Lockwood Greene has developed such models for the following Ironmaking Processes:

- Base Case Midrex Shaft Furnace
- Hylsa HYL IVM (Reformerless with Hot DRI Charge to EAF)
- Tecored Shaft Melter
- HiSmelt Oxygen Reactor
- Redsmelt Rotary Hearth Furnace
- Circored Fluid-Bed Reduction Process (Natural Gas Reductant)
- Circofer Fluid-Bed Reduction Process (Coal Reductant)
- Generic Iron Carbide Process (Single-Stage, Two-Stage or Multi-Stage)

The model outputs for a typical Ironmaking sensitivity cases for each model are presented in Appendix E.

What is important here is that these basic simulation models were used in this Study to evaluate and verify Vendor-Supplied heat and material balance data, production data and operating assumptions. Once verified, the MetSim models for the Ironmaking Processes were used to “tune” or adjust the Spreadsheet Models for the overall process (through EAF/LRF LRS) to provide realistic raw material, component and energy (fuel plus electrical power) balance systems.

This methodology is illustrated in Figure 2-2.2 below:



### 2-2.3 Spreadsheet Mass Balances of Process Components

As illustrated above, each of the raw material components utilized as feeds to the Ironmaking or Steelmaking processes were also defined by appropriate spreadsheet heat and material balances. These were prepared for the major components and also for the intermediate Unit Processes so that the cumulative fuel and electrical energy requirements could be accounted for. In addition, these component balance models provide the basis for defining the cumulative process carbon-gas emissions (all taken to be as CO<sub>2</sub>) for each process and process step to serve as relative indicators for comparison of the diverse Ironmaking Processes.

---

The spreadsheet model balance utilized for the components are provided in Appendix B for:

- Electrical Power Generation – Coal, Natural Gas & Fuel Oil (Basis for Cumulative Greenhouse Gas Emission per kWhr– As CO<sub>2</sub>)
- Lump Iron Ore
- Pelletizing Binder –Bentonite
- Coal
- Burnt Lime/Dolomite
- Oxygen Gas
- Carbon Electrode
- Co-Product (Conventional By-Product) Coke
- Non-Recovery Coke Process With Co-Generation (Based on Antaeus Energy Process)
- Other Raw Material Assumptions

#### 2-2.4 Spreadsheet Mass Balances of Ironmaking Processes

As illustrated above in Figure 2-2.2, the component mass balance spreadsheets are integrated with the Unit Process spreadsheets of the upstream operations preceding Ironmaking and Steelmaking. These, in turn, integrate with the detailed process spreadsheet mass balances for the individual Ironmaking Processes and the subsequent EAF/LRF operations to produce LRS.

The following examples of the totally-integrated process spreadsheets utilized in the study are illustrating the level of detail utilized to establish the process balances, define fuel and energy consumptions and estimate process emissions. The complete spreadsheet listings are provided in Appendix D:

- 100% DRI Charged to EAF - 1.0% Carbon
- 100% DRI Charged to EAF – 2.5% Carbon
- 30% DRI Charged to EAF - 1.0% Carbon
- 100% Scrap Charged to EAF (For Reference Only)

---

Spreadsheet summary balances were prepared for the major Ironmaking Process scenarios (i.e. various process types and EAF production scenarios for LRS) selected from the initial screening analysis. These provide the component quantities and logic from which process Operating Costs, emission estimates and energy consumptions are developed as a basis for process comparison.

Process descriptions of the Ironmaking Processes considered in the study are provided in Appendix A-1 and simplified Ironmaking Process Flow Diagrams (PFDs) are provided in Appendix A-2.

The Summary Spreadsheets for the process scenarios are provided in Appendix C:

#### **SHAFT FURNACE DRI – VARIATION IN CARBON AND SCRAP CHARGE**

- Base Case: 100% Shaft Furnace DRI (i.e. Midrex) Charge to EAF, 1.0 wt.% DRI (Recycle Steel Scrap Only)
- 100% Shaft Furnace DRI (i.e. Midrex) Charge to EAF, 2.5 wt.% Carbon (Recycle Steel Scrap Only)
- 100% Steel Scrap Charge to EAF (For Reference Only)
- 30% Shaft Furnace DRI/70% Scrap Charge to EAF (a Common Industry Practice), 1.0 wt.% DRI Carbon
- 30% Shaft Furnace DRI/70% Scrap Charge to EAF (a Common Industry Practice), 2.5 wt.% DRI Carbon
- Hylsa Shaft Furnace Without Reformer (HYL IVM), Hot DRI Charge to EAF

#### **HOT METAL VARIATIONS**

- 30% Blast Furnace Hot Metal/70% Scrap Charge to EAF, Co-Product Coke
- Mini Blast Furnace Comparison @ 30% H.M./70% Scrap Charge to EAF, Co-Product Coke



- 
- 30% Blast Furnace Hot Metal/70% Scrap Charge to EAF, Non-Recovery Coke
  - 30% Cold Pig Iron/70% Scrap Charge to EAF, 4.5% Carbon
  - 30% Tecnored Hot Metal/70% Scrap Charge to EAF, 4.5% Carbon H.M. With Integral Co-Generation of Electrical Power
  - 30% Tecnored Hot Metal/70% Scrap Charge to EAF, 4.5% Carbon H.M. Without Co-Generation of Electrical Power
  - Corex (VAI)/Midrex with 60% Hot Metal and 40% DRI Charge to EAF
  - HiSmelt (ISCON) with 34.5% Hot Metal Charge to EAF

#### **ROTARY HEARTH FURNACES**

- Redsmelt (Mannesmann) Hot Metal With Only Recycle Scrap Charge to EAF
- MauMee R&E Briquette DRI/EAF With Only Recycle Scrap Charge to EAF
- ITMK3 (Midrex RHF) to EAF With Only Recycle Scrap Charge to EAF

#### **FLUID-BED DRI/HBI**

- Circored (Lurgi)/HBI/EAF With Only Recycle Scrap Charge to EAF
- Circofer (Lurgi)/HBI/SAF/EAF With Only Recycle Scrap Charge to EAF
- Finmet (VAI)/HBI/EAF With Only Recycle Scrap Charge to EAF
- Generic Iron Carbide (ICH)/EAF With Only Recycle Scrap to EAF (Represents Nucor/ICH, Qualitech/Kawasaki, Procedyne Processes)
- 40% Iron Carbide Charge/60% Scrap to EAF (Believed to be Maximum Practical or Feasible Charge Ratio)

#### **OTHER PROCESSES**

- SL/RN (Stelco-Lurgi) Rotary Kiln With Only Recycle Scrap Charge to EAF

---

## **2-3: Base Process Location**

### **2-3.1 Base Location Assumptions**

In an initial screening of a number of Ironmaking process, both proven commercial and developing processes, it was recognized that the location of the process could have a significant impact on the technical and economic viability of that process. A number of factors related to location were considered to be potentially critical in evaluating and comparing processes. Some of these are related to raw material supply, others to proximity to markets for the products and some relate to local economic considerations of raw materials or labor costs.

These factors relating to location include:

- Proximity to ore source
- Proximity to pellet source (for those processes utilizing pellets)
- Local fuel (i.e. reductant) sources
- Costs, skills and productivity of local labor force
- Local market for product (assumed to be steel slabs from downstream Steelmaking operations)
- Availability of low-cost steel scrap sources of adequate purity for EAF Steelmaking
- Local environmental regulations, constraints, etc.

It was clear in the initial evaluation and screening of potential alternative ironmaking processes (to that of Blast Furnace Iron – hot metal or pig iron), that local proximity to low-cost reductant sources (i.e. either natural gas or appropriate coal resources) would be a significant swing variable in ranking of the potential alternate processes. This local proximity to fuel would not only impact on the choice of reductant type, it would influence the choice of process type, i.e. that which would utilize natural gas or that which would utilize coal as the primary reductant. These considerations are predominately economic, but could also be related to environmental impact or a desired steelmaking process iron unit feed.

---

### 2-3.2 Location Sensitivities

- Proximity to ore source

The most significant component of Operating Costs for the Ironmaking processes is the cost of iron units supplied to the process. Another factor is the form of the iron unit raw material delivered (i.e. as high-grade lump ore, pellets from iron ore concentrate or iron ore fines). A significant additional factor is the availability of supply of the desired iron unit raw material. All of these factors are related to the location of the Ironmaking process relative to the source of the iron unit raw material.

Since some Ironmaking process performance factors relate to the quality of the iron unit feed, close proximity to the source may provide a more favorable access to the most desirable feed material. This can impact the relative performance of one process over another. For example, there may be alternate methods of delivery (e.g. slurry pipeline) or availability of quantities at significantly-lower cost per iron unit for ore fines. Processes that can directly utilize them, perhaps without further beneficiation or palletizing, could have a local advantage.

Similarly, raw material cost factors (i.e. material handling and delivery costs, availability of low-cost fines, etc.) may influence significantly the choice of Ironmaking process. Availability of suitable port, rail or other delivery factors for raw materials and acceptable access to the raw material sources may partially mitigate a location-related factor for the iron unit feeds.

In this study, an upper Midwest U.S.A. location was chosen (i.e. Northern Ohio or Indiana) to provide a Target Location that would have all of the required factors for raw material delivery so as to not significantly bias the relative Ironmaking process evaluation and comparisons. Delivered raw material costs and availability are acceptable for that location and would not necessarily favor one process over another. However, in this fashion delivered costs of raw materials (including supply and transportation) were thus normalized, but not necessarily optimized, for all processes.

---

- Proximity to pellet source

For those processes utilizing indurated iron concentrate pellets, there could be significant impacts of location relative to the source of concentrates or direct reduction grade (DR) pellets. An ironmaking project that includes its own source of ore, concentrates and subsequent pellet production, may favor selection of an ironmaking process that benefits most directly by that constancy of feed quantity and quality. An example of this is the Shaft Furnace DRI processes, Midrex or Hylsa.

During high-iron production times, there could even be shortages of supply of the most desirable pellet feeds for some Ironmaking processes. Closeness to the source of pellets may present an advantage in availability or delivered cost. As described above, the choice of an upper Midwest U.S.A. location was designed to neither present an advantage or to be a disadvantage to the selection or comparison of Ironmaking processes.

- Local fuel sources

Second in importance related to Location, is that of the fuel (or reductant) source and/or type. There will definitely be advantages, similar to those for iron unit supply, to any of the Ironmaking processes is they can be located close to a readily-available, low-cost fuel supply. As noted above, the fuel supply (rate and quality) and delivered cost will be a primary consideration in the selection of the Ironmaking process type.

If low-cost coals of the proper type are available in a particular location versus a higher-cost supply of natural gas, this may influence the selection of a coal-based reductant ironmaking process. If metallurgical coal (for conventional coke production) is in short supply or is at a premium cost, selection of a process (e.g. rotary hearth, Tecnoled or non-recovery coking) that can utilize lower-cost, readily-available, low-rank coals may be the only process option. A similar situation where synthesis gas in quantity (i.e. Sasol Gas at Saldanha, SA.) is available may dictate the ironmaking process selection due to favorable fuel gas properties for that process.

In some locations, low-cost natural gas or suitable coal may not even be available locally. Thus, the relative costs of importing the quantities of fuel necessary could influence significantly the choice of Ironmaking process or

---

the overall project economics. The choice of an upper Midwest project location does not necessarily favor one fuel source over another.

- Costs, skills and productivity of local labor force

Labor costs as a fraction of the Operating Costs for iron or steel product are a relatively-low percentage ( $\approx 10\%$  or less of the totals). Differences in labor rates from one site location to the other would not significantly impact on the overall production costs. An important factor may be local labor productivity. In some countries, or in some regions of North America, effective productivity of labor not compensated for in the labor rates, may have an impact on the costs of production for some of the Ironmaking processes. There are significant differences in the manpower requirements for some of the ironmaking scenarios (when normalized to North American standards) that could influence the choice of process or overall project economics.

More importantly, however, some Ironmaking processes, in particular those higher-technology processes in development or in their first-of-a-kind prototype phase, could require a more highly-skilled labor force to operate or maintain. This may not be readily available, would command an extraordinarily-high premium on labor rates or would require importation of skilled labor for some processes in some locations. This could influence significantly the choice of process related to a specific location.

The upper Midwest location should neither present an advantage nor a disadvantage to any specific Ironmaking process. It would have an overall favorable labor market due to the high skill and experience levels of the available work force and a general familiarity with heavy industrial processes such as ironmaking and steelmaking.

- Local market for product

In general, the upper Midwest U.S.A. location would be a favorable one for a steel slab product produced from any of the Ironmaking processes. The ability of some Ironmaking processes (particularly those producing DRI) to produce a favorably low impurity scrap substitute iron feed, could favor the production of low-impurity steel for specific industry (e.g. deep drawing quality auto body grades, etc.). However, the market for all types of steel

---

from this general location would not favor one type of process over the other.

Shipment or transportation of the finished steel slab product would also be generally favorable with options including water shipment, rail or truck shipment of the steel product. There is also the possibility of close integration with an existing customer for a steel slab product that would eliminate the necessity of product shipping.

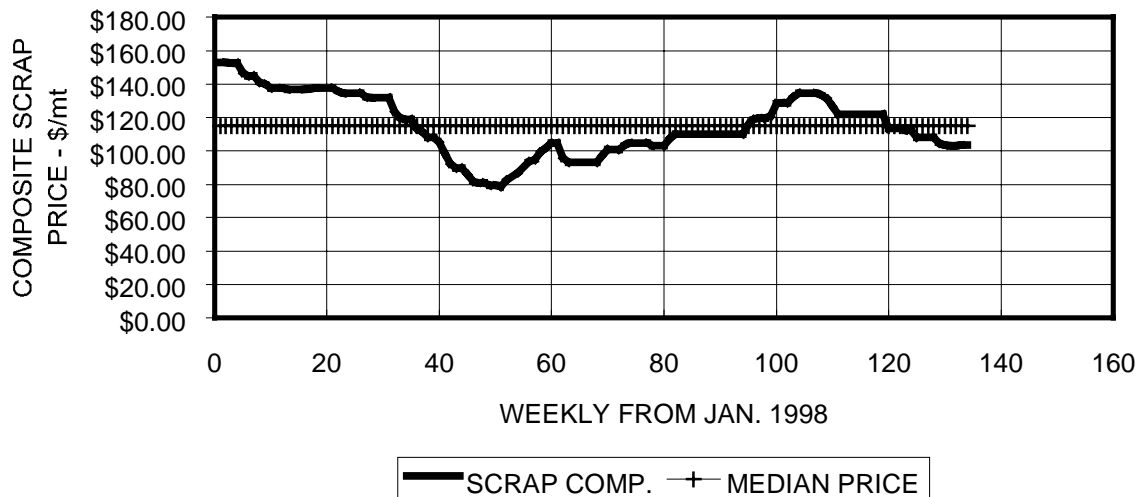
- Availability of low-cost steel scrap

A significant finding of this Alternative Ironmaking Study is that the selection of an Ironmaking process (for ultimate EAF/LRF steelmaking) is directly influenced by the availability, cost and purity of steel scrap. This is not only a significant factor in the selection of the appropriate Ironmaking process, but in the net final cost of the final LRS product. It may be that those ironmaking processes that most efficiently combine with the EAF steelmaking to minimize the quantity or quality (i.e. costs or availability) of steel scrap would be the only economically-viable Ironmaking processes of choice in a high cost steel scrap market.

Discussed in Section 2-4 and in Section 4, the steel scrap price sensitivity is a primary factor in Ironmaking process selection. With the fluctuation in steel scrap prices with the past two years over a range of approximately +/- 50% from the average (see Figure 2-3.1 below), ironmaking processes (in combination with EAF/LRF) that are viable at median or lower scrap prices are not viable at the above average scrap price.

Steelmaking that requires a higher scrap charge would have a net result of higher steelmaking costs.

FIGURE 2-3.1: STEEL SCRAP PRICE COMPOSITE  
(\$/mt WEEKLY FROM JANUARY 1998)



This also works against those Ironmaking processes that are designed to be scrap substitutes, i.e. DRI producers such as the shaft furnaces. It is a true perspective that Shaft Furnace DRI facilities that were installed just one or two years ago under a favorable economic climate (e.g. moderate scrap prices) became uneconomically viable and with no competitive market at low scrap prices.

- Local environmental regulations, constraints, etc.

A key part of the initial evaluation and process screening phases of this Alternative Ironmaking Study was the overall impact on greenhouse gas emissions for each process (as represented in the Study by total the cumulative carbon gas emissions as CO<sub>2</sub>). Not only is this factor an important one in comparing the various processes, it is one that could impact on the ability to install a particular process at a specific location.

There are several forces are working against each other. One is that the total local emissions for a given process may exceed the Local environment

---

regulatory standards or limits; thus prohibiting selection of that process for that specific location or requiring extra-ordinary mitigation and control. A second factor is that of the cumulative total emissions for the entire train of the process (i.e. ore mining, concentration, pelletizing, etc.) may be high and thus would have a broad impact on the total environment. A last environmental factor is that the total electrical power requirements for a process are high. This also would have a broad impact on the total environment since there are significant emissions (on the average for a U.S.A. location, See Appendix A-3.1) associated with electrical power generation that cannot be ignored when comparing processes to produce LRS.

It will be noted in the comparative analysis below (Section 4-7) that coal-based reductant processes typically have significantly more emissions (as CO<sub>2</sub>) than natural gas reductant processes. A local environmental restriction or constraint may dictate the use of an Ironmaking process with lower local emission levels.

Two specific ironmaking scenarios were evaluated in this Study where there is a significant difference of the impact of emissions from the coking production processes. The production of coke for use in a blast furnace is a significant contributor to the overall emissions of the blast furnace process. The first scenario is one that the conventional Blast Furnace process produces hot metal utilizing conventional co-product coke production. The second is one where the blast furnace produces hot metal utilizing an evolving, continuous non-recovery coke production process. For these cases, no differences in the blast furnace productivity or charge requirements were assumed as a result of the use of one type of coke or the other.

(Note: Physical and chemical parameters for the briquetted form coke produced by the non-recovery process may indicate that, in fact, the blast furnace productivity could be higher.)

The comparison of the total emissions for these two, otherwise identical, cases indicated that there was approximately a 7% lower total emissions from the Non-Recovery Coke/Blast Furnace process relative to the Conventional Co-Product Coke/Blasé Furnace. With the inclusion of co-generation that is an integral part of the Continuous Non-Recovery Coke



---

process, there was a 22% reduction in emissions due to total cumulative electrical power related emissions. This kind of environmental difference may provide incentives or constraints to utilize the lower-emitting technologies.

## **2-4: Process Capital (CAPEX) and Operating Cost Estimates**

### **2-4.1: Process Capital Costs (CAPEX)**

The Relative Capital Cost (CAPEX) estimates for each of the Alternative Ironmaking Processes were developed from appropriate Iron and Steelmaking Unit Operation internal LGE Cost, Feasibility or Detailed Design Studies. In addition, some specific Process Vendor inputs were utilized to provide a most recent estimate basis or where the appropriate in-house data were not available. The installed cost estimates were factored using internal LGE factors for the costs for similar scopes for process areas or plant type for each of the Ironmaking Processes. Where common cost areas are present for different Ironmaking processes, e.g. pelletizing plant, the basis costs were factored for each Ironmaking process according to capacity requirements.

The costs used were updated to a year 2000 basis and normalized using the process Mass Balances (Appendix C) to a uniform 1.0 million metric tonnes per year Refined Liquid Steel (RLS) production basis. Specific differences in scope required for a particular Ironmaking process were accounted for in the individual components considered in the overall process CAPEX estimates (summarized in detail in Volume II, Appendix F-5). The CAPEX is reported as \$/annual metric tonne of production.

The analysis of the relative CAPEX estimates for the various Ironmaking process scenarios will be presented in Section 4.2.

The built-up CAPEX costs are presented in Appendix F-5 and are summarized in the Table 2-4.1 below:

**Table 2-4.1**

<b>CAPITAL COST ESTIMATES - IRONMAKING AND EAF/LRF PROCESSES</b>		
<b>APPENDIX NO.</b>	<b>PROCESS</b>	<b>CAPEX (\$/ANNUAL mt L.S.)</b>
<b>SHAFT FURNACE DRI PROCESSES:</b>		
C-1	100% Shaft Furnace DRI charge to EAF, 1.0 wt.% Carbon	\$365.36
C-2	100% Shaft Furnace DRI charge to EAF, 2.5 wt.% Carbon	\$365.45
C-3	100% Steel Scrap charge to EAF	\$173.68
C-4	30% Shaft Furnace DRI/70% Scrap to EAF, 1.0 wt.% DRI Carbon	\$231.85
C-5	30% Shaft Furnace DRI/70% Scrap to EAF, 2.5 wt.% DRI Carbon	\$232.70
C-6	HYLSA Shaft Furnace without reformer, Hot DRI charge to EAF	\$362.60
<b>HOT METAL VARIATIONS</b>		
C-7	30% Blast Furnace Hot Metal/70% Scrap to EAF, Co-Product Coke	\$243.64
C-7a	30% Blast Furnace Hot Metal/70% Scrap to EAF, Mini Blast Fce.	\$198.05
C-8	30% Blast Furnace Hot Metal/70% Scrap to EAF, Non-Recov. Coke	\$243.63
C-9	30% Cold Pig Iron/70% Scrap to EAF, 4.5% Carbon Pig	\$248.06
C-10	30% Technored Hot Metal/70% Scrap to EAF, with Co-Generation	\$196.48
C-11	30% Technored Hot Metal/70% Scrap to EAF, without Co-Gen.	\$187.71
C-12	COREX/MIDREX with 60% Hot Metal/40% DRI charge to EAF	\$373.50
C-13	HISMELT with 32.7% Hot Metal charge to EAF	\$259.63
<b>ROTARY HEARTH FURNACES</b>		
C-14	REDSMELT Hot Metal with only Recycle Scrap to EAF	\$334.67
C-15	MAUMEE Briquette DRI/EAF with only Recycle Scrap to EAF	\$292.32
C-16	ITMK3 to EAF with only recycle scrap charge to EAF	\$296.10
<b>FLUID-BED DR/HBI</b>		
C-17	CIRCORED/HBI/EAF with only Recycle Scrap charge to EAF	\$232.37
C-18	CIRCOFER/HBI/SAF/EAF with only Recycle Scrap charge to EAF	\$239.63
C-19	FINMET/HBI/EAF with only Recycle Scrap Charge to EAF	\$263.47
C-20a	Generic IRON CARBIDE/EAF with only Recycle Scrap to EAF	\$347.59
C-20b	Generic IRON CARBIDE/EAF with 60% Scrap charge to EAF	\$257.24
<b>OTHER PROCESSES</b>		
C-21	SL/RN Rotary Kiln with only Recycle Scrap charge to EAF	\$344.39

---

## 2-4.2 Process Operating Costs (OPEX)

The approach followed in developing the operating costs for the various Ironmaking Processes was to build up the operating costs (OPEX) from the individual components of each process scenario.

The bases for these costs include:

- Consumable components as defined by the mass and fuel balances (Appendix B).
- Electrical power consumptions from experience or Process Vendor data.
- Labor estimates were factored from man-hour/mt data supplied by Process Vendors and from LGE experience with similar processes.
- Costs and/or fuel costs for transport of materials.
- Allowances for maintenance materials and supplies based on Vendor factors.
- As appropriate, allowances for G&A were added.

Each process component cost was built up using the above factors for each unit operation involved in producing and delivering the consumable to the ironmaking process.

In tables in Appendix F-1, the Consumable Component costs are defined and summarized for:

- Bentonite Binder
- Coal (lump delivered to use)
- Burnt Lime/Dolomite
- Lump Iron Ore
- Fine Iron Ore
- Iron Ore Concentrate
- Iron Ore Pellets
- Co-Product Coke Production

- 
- Non-Recovery Coke/with Co-Generation
  - Steel Scrap Composite Price Basis

### 2-4.3 Ironmaking Process Consumptions & Relative Operating Costs

The Ironmaking Process Consumptions and their Relative Operating Costs are built up from the costs of the various consumable materials in a similar manner.

- Consumable components as defined by the mass and fuel balances for the Ironmaking Processes (Appendices C & D).
- Electrical power consumptions from experience or Process Vendor data.
- Labor estimates were factored from man-hour/mt data supplied by Process Vendors and from LGE's in-house experience for similar processes.
- Costs for transport of materials included in material costs.
- Allowances for maintenance materials and supplies based on Vendor factors.
- Other consumable cost assumptions, e.g. composite steel scrap; overall labor cost per man-hour, natural gas, electrical power, and other delivered materials are based on an upper Mid-West U.S.A. location. These were derived from negotiated commodity costs achieved for a recent large-scale project in that region. (Note: Costs for electrical power, fuel, etc. were first-quarter 2000. They were not changed due to recent escalations. It is believed that most relative comparisons will still be valid.)
- As appropriate, allowances for G&A and/or Vendor fees were added.

Each Ironmaking Process Cost was derived from the summation of the individual costs of each unit operation involved in producing the Iron Units and subsequent production of EAF/LRF Refined Steel Product.

The Process Operating Costs, (OPEX), developed in the above fashion are believed to be relatively precise as a basis for comparing the various processes on an equalized footing. By normalizing all processes through the production of the Refined Liquid Steel product, all types of iron units

---

produced by the Ironmaking Processes can be compared. Thus hot metal producing processes are comparable on an equalized basis to direct reduced iron producing processes. The relative accuracy of each of the components of the OPEX based on closure of the mass balances should produce a fair overall cost for each process that can be compared accurately to each other.

It is also believed that the absolute accuracy of these OPEX costs is also relatively precise. Spot checks of the estimated costs and comparisons with recent detailed feasibility studies using Vendor data of these and similar processes have verified the accuracy of the built up operating cost calculation procedure.

The Table 2-4.2 provides a summary of the primary Ironmaking Process Operating Costs (as presented in detail in Volume II, Appendix F-4):

**Table 2-4.2**

<b>OPERATING COST ESTIMATES - IRONMAKING AND EAF/LRF PROCESSES</b>			
<b>APPENDIX NO.</b>	<b>PROCESS</b>	<b>OPEX FOR I.U. (\$/ANN. mt I.U.)</b>	<b>OPEX FOR L.S. (\$/ANN. mt L.S.)</b>
<b>SHAFT FURNACE DRI PROCESSES:</b>			
C-1	100% Shaft Furnace DRI charge to EAF, 1.0 wt.% Carbon	\$132.44	\$205.39
C-2	100% Shaft Furnace DRI charge to EAF, 2.5 wt.% Carbon	\$132.55	\$206.42
C-3	100% Steel Scrap charge to EAF	\$0.00	\$197.39
C-4	30% Shaft Furnace DRI/70% Scrap to EAF, 1.0 wt.% DRI Carbon	\$137.51	\$203.36
C-5	30% Shaft Furnace DRI/70% Scrap to EAF, 2.5 wt.% DRI Carbon	\$136.14	\$204.72
C-6	HYLSA Shaft Furnace without reformer, Hot DRI charge to EAF	\$125.52	\$196.15
<b>HOT METAL VARIATIONS</b>			
C-7	30% Blast Furnace Hot Metal/70% Scrap to EAF, Co-Product Coke	\$142.86	\$204.39
C-7a	30% Blast Furnace Hot Metal/70% Scrap to EAF, Mini Blast Fce.	\$142.86	\$204.39
C-8	30% Blast Furnace Hot Metal/70% Scrap to EAF, Non-Recov. Coke	\$110.77	\$192.97
C-9	30% Cold Pig Iron/70% Scrap to EAF, 4.5% Carbon Pig	\$145.12	\$212.79
C-10	30% Technored Hot Metal/70% Scrap to EAF, with Co-Generation	\$125.95	\$192.41
C-11	30% Technored Hot Metal/70% Scrap to EAF, without Co-Gen.	\$163.09	\$205.72
C-12	COREX/MIDREX with 60% Hot Metal/40% DRI charge to EAF	\$208.88	\$228.34
C-13	HISMELT with 32.7% Hot Metal charge to EAF	\$137.85	\$198.19
<b>ROTARY HEARTH FURNACES</b>			
C-14	REDSMELT Hot Metal with only Recycle Scrap to EAF	\$101.83	\$190.67
C-15	MAUMEE Briquette DRI/EAF with only Recycle Scrap to EAF	\$66.44	\$177.03
C-16	ITMK3 to EAF with only recycle scrap charge to EAF	\$67.60	\$181.12
<b>FLUID-BED DRI/HBI</b>			
C-17	CIRCORED/HBI/EAF with only Recycle Scrap charge to EAF	\$78.79	\$185.27
C-18	CIRCOFER/HBI/SAF/EAF with only Recycle Scrap charge to EAF	\$96.20	\$188.55
C-19	FINMET/HBI/EAF with only Recycle Scrap Charge to EAF	\$79.42	\$185.12
C-20a	Generic IRON CARBIDE/EAF with only Recycle Scrap to EAF	\$66.19	\$177.84
C-20b	Generic IRON CARBIDE/EAF with 60% Scrap charge to EAF	\$100.79	\$192.65
<b>OTHER PROCESSES</b>			
C-21	SL/RN Rotary Kiln with only Recycle Scrap charge to EAF	\$74.08	\$183.10

Basis: \$120/mt Composite Steel Scrap Cost

The Ironmaking Process Operating Cost details are summarized in Appendix F-4 for the following process scenarios:

---

## SHAFT FURNACE DRI PROCESSES

- Base Process Shaft Furnace (i.e. Midrex), 100% DRI charge to EAF, 1.0 wt.% DRI Carbon (Appendix C-1)
- Base Process Shaft Furnace (i.e. Midrex), 100% DRI charge to EAF, 2.5 wt.% DRI Carbon (for reference, Appendix C-2)
- Electric Arc Furnace Steelmaking, 100% Steel Scrap Charge (for reference, Appendix C-3)
- Base Process Shaft Furnace (i.e. Midrex), 30% DRI/70% Steel Scrap charge to EAF (a common industry practice), 1.0 wt.% DRI Carbon (Appendix C-4)
- Base Process Shaft Furnace (i.e. Midrex), 30 % DRI/70% Steel Scrap charge to EAF (for reference, Appendix C-5)
- HYLSA IVM Shaft Furnace without reformer, 100% hot DRI charge to EAF, (Appendix C-6)

## HOT METAL VARIATIONS

- Blast Furnace Hot Metal (30% H.M./70% Steel Scrap charge to EAF), Conventional Co-Product Coke (Appendix C-7)
- Mini Blast Furnace Comparison (30% H.M./70% Steel Scrap charge to EAF), Co-Product Coke
- Blast Furnace Hot Metal (30% H.M./70% Steel Scrap charge to EAF), Non-Recovery Coking process with Co-Generation (for comparison, Appendix C-8)
- Cold Pig Iron (30% P.I./70% Steel Scrap charge to EAF), Conventional Co-Product Coke (Appendix C-9)
- Tecnored Hot Metal (30% H.M./70% Steel Scrap charge to EAF) with integral Co-Generation of Electrical Power (Appendix C-10)
- Tecnored Hot Metal (30% H.M./70% Steel Scrap charge to EAF) without Co-Generation of Electrical Power (Appendix C-11)
- Corex (VAI)/Midrex Shaft Furnace combination process, 60% H.M./40% DRI charge to EAF (Appendix C-12)

- 
- HiSmelt Enriched Oxygen Reactor Process, 32.7% H.M. feed to EAF (Appendix C-13)

### **ROTARY HEARTH DRI FURNACES**

- REDSMELT (Mannesmann) process to produce RHF DRI, Hot Metal utilizing a SAF, recycle scrap only charge to EAF (Appendix C-14)
- MauMee Research & Engineering Briquette DRI charge (100% with only recycle scrap charge to EAF) (Appendix C-15)
- ITMK3 (Midrex RHF) process producing reduced shot iron pellets charge to Melter/EAF (100% with only recycle scrap charge to EAF) (Appendix C-16) (Note: Other Rotary Hearth Processes, e.g. Inmetco, Iron Dynamics, FastMet/FastMelt, etc. are so generically similar to those above, that they were not individually considered.)

### **FLUID-BED DRI/HBI**

- Circored (Lurgi) natural gas based circulating fluid bed/bubbling bed fine ore process with 100% HBI charge to EAF (Appendix C-17)
- Circofer (Lurgi) fine coal and fine ore circulating fluid bed/bubbling bed with HBI charge to SAF and low-carbon, low-Si H.M. charge to EAF (Appendix C-18)
- Finmet (VAI) multi-stage fluidized bed fine ore process, natural gas based, 100% HBI charge to EAF (Appendix C-19)
- Generic Iron Carbide Process (to represent all process variations and/or configurations) with 100% IC charge to EAF (Appendix C-20)
- Generic Iron Carbide Process with 40% IC/60% Scrap charge to EAF (considered to be a practical limit for charging iron carbide to the EAF)

### **OTHER PROCESSES**

- SL/RN (Stelco-Lurgi) Rotary Kiln reduction process to produce 100% sponge iron charge to EAF with only recycled Scrap (Appendix C-21)



**Table 2-4.3**  
**(\$100/mt Scrap Cost Sensitivity)**  
**SUMMARY OF RELATIVE OPERATING COSTS - IRONMAKING PROCESSES**

SENSITIVITY: \$100.00/mt STEEL SCRAP PRICE

SEQ. NO.	PROCESS	COST PER NET MT LIQUID STEEL								
		ORE, OTHER IRON UNITS	CONC. DELIVERED	PELLETIZING/ BRIQUETTING	REDUCTION	HOT METAL PROD.	PURCHASED EAF SCRAP	EAF STEELMKG.	LADLE REFINING	TOTAL LIQ. STEEL
<b>SHAFT FURNACE DRI PROCESSES:</b>										
C-1	100% SHAFT FURNACE DRI CHARGE TO EAF, 1.0 WT.% CARBON		\$64.31	\$24.10	\$49.99			\$60.17	\$6.82	\$205.39
C-2	100% SHAFT FURNACE DRI CHARGE TO EAF, 2.5 WT.% CARBON		\$64.39	\$24.13	\$49.99			\$61.09	\$6.82	\$206.42
C-3	100% STEEL SCRAP CHARGE TO EAF						\$102.80	\$67.21	\$6.82	\$176.83
C-4	30% SHAFT FURNACE DRI/70% SCRAP TO EAF, 1.0 WT.% DRI CARBON		\$21.33	\$10.30	\$16.87		\$73.64	\$59.68	\$6.82	\$188.64
C-5	30% SHAFT FURNACE DRI/70% SCRAP TO EAF, 2.5 WT.% DRI CARBON		\$21.34	\$10.31	\$17.14		\$73.64	\$60.73	\$6.82	\$189.99
C-6	HLYSA SHAFT FURNACE WITHOUT REFORMER, HOT DRI CHARGE TO EAF		\$64.31	\$24.10	\$42.76			\$58.16	\$6.82	\$196.15
<b>HOT METAL VARIATIONS</b>										
C-7	30% BLAST FURNACE HOT METAL/70% SCRAP TO EAF, CO-PRODUCT COKE	\$3.99	\$18.45			\$32.75	\$73.66	\$53.98	\$6.82	\$189.65
C-8	30% BLAST FURNACE HOT METAL/70% SCRAP TO EAF, N.R. COKE	\$4.07	\$10.29			\$29.41	\$73.66	\$53.98	\$6.82	\$178.23
C-9	30% COLD PIG IRON/70% SCRAP TO EAF, 4.5% CARBON PIG	\$3.99	\$18.45			\$33.56	\$73.66	\$61.57	\$6.82	\$198.05
C-10	30% TECNORED HOT METAL/70% SCRAP TO EAF, WITH CO-GENERATION			\$21.28		\$23.86	\$73.66	\$52.05	\$6.82	\$177.67
C-11	30% TECNORED HOT METAL/70% SCRAP TO EAF, WITHOUT CO-GENERATION			\$21.28		\$37.17	\$73.66	\$52.05	\$6.82	\$190.98
C-12	COREX/MIDREX WITH 60% HOT METAL 40% DRI CHARGE TO EAF	\$41.73		\$34.17	\$10.67	\$75.27		\$49.51	\$6.82	\$218.17
C-13	HISMELT WITH 32.7% HOT METAL TO CHARGE TO EAF		\$23.46			\$25.96	\$81.03	\$52.06	\$8.31	\$190.82

## SUMMARY OF RELATIVE OPERATING COSTS - IRONMAKING PROCESSES

SENSITIVITY: \$100.00/mt STEEL SCRAP PRICE

SEQ. NO.	PROCESS	COST PER NET MT LIQUID STEEL								
		ORE, OTHER IRON UNITS	CONC. DELIVERED	PELLETIZING/ BRIQUETTING	REDUCTION	HOT METAL PROD.	PURCHASED EAF SCRAP	EAF STEELMKG.	LADLE REFINING	TOTAL LIQ. STEEL
<b>ROTARY HEARTH FURNACES</b>										
C-14	REDSMELT HOT METAL WITH ONLY RECYCLE SCRAP CHARGE TO EAF	\$30.80		\$31.78	\$22.33	\$38.68	\$11.81	\$46.24	\$6.67	\$188.31
C-15	MAUMEE BRIQUETTE DRI/EAF WITH ONLY RECYCLE SCRAP CHARGE TO EAF	\$32.41		\$41.93	\$32.60			\$60.97	\$9.12	\$177.03
C-16	ITMK3 TO EAF WITH ONLY RECYCLE SCRAP CHARGE TO EAF	\$30.80		\$38.46	\$30.90		\$11.81	\$58.47	\$8.32	\$178.76
<b>FLUID-BED DRI/HBI</b>										
C-17	CIRCORED/HBI/EAF WITH ONLY RECYCLE SCRAP CHARGE TO EAF	\$37.95		\$7.58	\$78.22			\$55.60	\$5.92	\$185.27
C-18	CIRCOFER/HBI/SAF/EAF WITH ONLY RECYCLE SCRAP CHARGE TO EAF	\$36.80		\$15.08	\$51.00	\$38.68		\$40.33	\$6.66	\$188.55
C-19	FINMET/HBI/EAF WITH ONLY RECYCLE SCRAP CHARGE TO EAF	\$37.11		\$6.77	\$79.72			\$55.60	\$5.92	\$185.12
C-20a	GENERIC IRON CARBIDE/EAF RECYCLE SCRAP CHARGE TO EAF	\$36.05			\$81.34			\$54.53	\$5.92	\$177.84
C-20b	GENERIC IRON CARBIDE/SAF/EAF 60% SCRAP CHARGE TO EAF	\$14.42			\$32.54	\$17.01	\$63.75	\$45.52	\$6.66	\$179.90
<b>OTHER PROCESSES</b>										
C-21	SL/RN ROTARY KILN WITH ONLY RECYCLE SCRAP CHARGE TO EAF	\$28.73		\$49.07	\$20.31		\$11.81	\$61.73	\$9.09	\$180.74

**Table 2-4.4**  
**(\$120/mt Scrap Cost Sensitivity)**  
**SUMMARY OF RELATIVE OPERATING COSTS - IRONMAKING PROCESSES**

SENSITIVITY: \$120.00/mt STEEL SCRAP PRICE

SEQ. NO.	PROCESS	COST PER NET MT LIQUID STEEL								
		ORE, OTHER IRON UNITS	CONC. DELIVERED	PELLETIZING/ BRIQUETTING	REDUCTION	HOT METAL PROD.	PURCHASED EAF SCRAP	EAF STEELMKG.	LADLE REFINING	TOTAL LIQ. STEEL
<b>SHAFT FURNACE DRI PROCESSES:</b>										
C-1	100% SHAFT FURNACE DRI CHARGE TO EAF, 1.0 WT.% CARBON		\$64.31	\$24.10	\$49.99			\$60.17	\$6.82	\$205.39
C-2	100% SHAFT FURNACE DRI CHARGE TO EAF, 2.5 WT.% CARBON		\$64.39	\$24.13	\$49.99			\$61.09	\$6.82	\$206.42
C-3	100% STEEL SCRAP CHARGE TO EAF						\$123.36	\$67.21	\$6.82	\$197.39
C-4	30% SHAFT FURNACE DRI/70% SCRAP TO EAF, 1.0 WT.% DRI CARBON		\$21.33	\$10.30	\$16.87		\$88.36	\$59.68	\$6.82	\$203.36
C-5	30% SHAFT FURNACE DRI/70% SCRAP TO EAF, 2.5 WT.% DRI CARBON		\$21.34	\$10.31	\$17.14		\$88.37	\$60.73	\$6.82	\$204.72
C-6	HYLSA SHAFT FURNACE WITHOUT REFORMER, HOT DRI CHARGE TO EAF		\$64.31	\$24.10	\$42.76			\$58.16	\$6.82	\$196.15
<b>HOT METAL VARIATIONS</b>										
C-7	30% BLAST FURNACE HOT METAL/70% SCRAP TO EAF, CO-PRODUCT COKE	\$3.99	\$18.45			\$32.75	\$88.40	\$53.98	\$6.82	\$204.39
C-8	30% BLAST FURNACE HOT METAL/70% SCRAP TO EAF, N.R. COKE	\$4.07	\$10.29			\$29.41	\$88.40	\$53.98	\$6.82	\$192.97
C-9	30% COLD PIG IRON/70% SCRAP TO EAF, 4.5% CARBON PIG	\$3.99	\$18.45			\$33.56	\$88.40	\$61.57	\$6.82	\$212.79
C-10	30% TECNORED HOT METAL/70% SCRAP TO EAF, WITH CO-GENERATION			\$21.28		\$23.86	\$88.40	\$52.05	\$6.82	\$192.41
C-11	30% TECNORED HOT METAL/70% SCRAP TO EAF, WITHOUT CO-GENERATION			\$21.28		\$37.17	\$88.40	\$52.05	\$6.82	\$205.72
C-12	COREX/MIDREX WITH 60% HOT METAL 40% DRI CHARGE TO EAF	\$41.73		\$34.17	\$10.67	\$75.27		\$49.51	\$6.82	\$218.17
C-13	HISMELT WITH 32.7% HOT METAL TO CHARGE TO EAF		\$23.46			\$25.96	\$88.40	\$52.06	\$8.31	\$198.19

## SUMMARY OF RELATIVE OPERATING COSTS - IRONMAKING PROCESSES

SENSITIVITY: \$120.00/mt STEEL SCRAP PRICE

SEQ. NO.	PROCESS	COST PER NET MT LIQUID STEEL								
		ORE, OTHER IRON UNITS	CONC. DELIVERED	PELLETIZING/ BRIQUETTING	REDUCTION	HOT METAL PROD.	PURCHASED EAF SCRAP	EAF STEELMKG.	LADLE REFINING	TOTAL LIQ. STEEL
<b>ROTARY HEARTH FURNACES</b>										
C-14	REDSMELT HOT METAL WITH ONLY RECYCLE SCRAP CHARGE TO EAF	\$30.80		\$31.78	\$22.33	\$38.68	\$14.17	\$46.24	\$6.67	\$190.67
C-15	MAUMEE BRIQUETTE DR/EAF WITH ONLY RECYCLE SCRAP CHARGE TO EAF	\$32.41		\$41.93	\$32.60			\$60.97	\$9.12	\$177.03
C-16	ITMK3 TO EAF WITH ONLY RECYCLE SCRAP CHARGE TO EAF	\$30.80		\$38.46	\$30.90		\$14.17	\$58.47	\$8.32	\$181.12
<b>FLUID-BED DR/HBI</b>										
C-17	CIRCORED/HBI/EAF WITH ONLY RECYCLE SCRAP CHARGE TO EAF	\$37.95		\$7.58	\$78.22			\$55.60	\$5.92	\$185.27
C-18	CIRCOFER/HBI/SAF/EAF WITH ONLY RECYCLE SCRAP CHARGE TO EAF	\$36.80		\$15.08	\$51.00	\$38.68		\$40.33	\$6.66	\$188.55
C-19	FINMET/HBI/EAF WITH ONLY RECYCLE SCRAP CHARGE TO EAF	\$37.11		\$6.77	\$79.72			\$55.60	\$5.92	\$185.12
C-20a	GENERIC IRON CARBIDE/EAF RECYCLE SCRAP CHARGE TO EAF	\$36.05			\$81.34			\$54.53	\$5.92	\$177.84
C-20b	GENERIC IRON CARBIDE/SAF/EAF 60% SCRAP CHARGE TO EAF	\$14.42			\$32.54	\$17.01	\$76.50	\$45.52	\$6.66	\$192.65
<b>OTHER PROCESSES</b>										
C-21	SL/RN ROTARY KILN WITH ONLY RECYCLE SCRAP CHARGE TO EAF	\$28.73		\$49.07	\$20.31		\$14.17	\$61.73	\$9.09	\$183.10

**Table 2-4.5**  
**(\$140/mt Scrap Cost Sensitivity)**  
**SUMMARY OF RELATIVE OPERATING COSTS - IRONMAKING PROCESSES**

SENSITIVITY: \$140.00/mt STEEL SCRAP PRICE

SEQ. NO.	PROCESS	COST PER NET MT LIQUID STEEL								
		ORE, OTHER IRON UNITS	CONC. DELIVERED	PELLETIZING/ BRIQUETTING	REDUCTION	HOT METAL PROD.	PURCHASED EAF SCRAP	EAF STEELMKG.	LADLE REFINING	TOTAL LIQ. STEEL
<b>SHAFT FURNACE DRI PROCESSES:</b>										
C-1	100% SHAFT FURNACE DRI CHARGE TO EAF, 1.0 WT.% CARBON		\$64.31	\$24.10	\$49.99			\$60.17	\$6.82	\$205.39
C-2	100% SHAFT FURNACE DRI CHARGE TO EAF, 2.5 WT.% CARBON		\$64.39	\$24.13	\$49.99			\$61.09	\$6.82	\$206.42
C-3	100% STEEL SCRAP CHARGE TO EAF						\$143.92	\$67.21	\$6.82	\$217.95
C-4	30% SHAFT FURNACE DRI/70% SCRAP TO EAF, 1.0 WT.% DRI CARBON		\$21.33	\$10.30	\$16.87		\$103.09	\$59.68	\$6.82	\$218.09
C-5	30% SHAFT FURNACE DRI/70% SCRAP TO EAF, 2.5 WT.% DRI CARBON		\$21.34	\$10.31	\$17.14		\$103.10	\$60.73	\$6.82	\$219.45
C-6	HYLSA SHAFT FURNACE WITHOUT REFORMER, HOT DRI CHARGE TO EAF		\$64.31	\$24.10	\$42.76			\$58.16	\$6.82	\$196.15
<b>HOT METAL VARIATIONS</b>										
C-7	30% BLAST FURNACE HOT METAL/70% SCRAP TO EAF, CO-PRODUCT COKE	\$3.99	\$18.45			\$32.75	\$103.13	\$53.98	\$6.82	\$219.12
C-8	30% BLAST FURNACE HOT METAL/70% SCRAP TO EAF, N.R. COKE	\$4.07	\$10.29			\$29.41	\$103.13	\$53.98	\$6.82	\$207.70
C-9	30% COLD PIG IRON/70% SCRAP TO EAF, 4.5% CARBON PIG	\$3.99	\$18.45			\$33.56	\$103.13	\$61.57	\$6.82	\$227.52
C-10	30% TECNORED HOT METAL/70% SCRAP TO EAF, WITH CO-GENERATION			\$21.28		\$23.86	\$103.13	\$52.05	\$6.82	\$207.14
C-11	30% TECNORED HOT METAL/70% SCRAP TO EAF, WITHOUT CO-GENERATION			\$21.28		\$37.17	\$103.13	\$52.05	\$6.82	\$220.45
C-12	COREX/MIDREX WITH 60% HOT METAL 40% DRI CHARGE TO EAF	\$41.73		\$34.17	\$10.67	\$75.27		\$49.51	\$6.82	\$218.17
C-13	HISMELT WITH 32.7% HOT METAL TO CHARGE TO EAF		\$23.46			\$25.96	\$103.13	\$52.06	\$8.31	\$212.92

## SUMMARY OF RELATIVE OPERATING COSTS - IRONMAKING PROCESSES

SENSITIVITY: \$140.00/mt STEEL SCRAP PRICE

SEQ. NO.	PROCESS	COST PER NET MT LIQUID STEEL								
		ORE, OTHER IRON UNITS	CONC. DELIVERED	PELLETIZING/ BRIQUETTING	REDUCTION	HOT METAL PROD.	PURCHASED EAF SCRAP	EAF STEELMKG.	LADLE REFINING	TOTAL LIQ. STEEL
<b>ROTARY HEARTH FURNACES</b>										
C-14	REDSMELT HOT METAL WITH ONLY RECYCLE SCRAP CHARGE TO EAF	\$30.80		\$31.78	\$22.33	\$38.68	\$16.53	\$46.24	\$6.67	\$193.03
C-15	MAUMEE BRIQUETTE DRI/EAF WITH ONLY RECYCLE SCRAP CHARGE TO EAF	\$32.41		\$41.93	\$32.60			\$60.97	\$9.12	\$177.03
C-16	ITMK3 TO EAF WITH ONLY RECYCLE SCRAP CHARGE TO EAF	\$30.80		\$38.46	\$30.90		\$16.53	\$58.47	\$8.32	\$183.48
<b>FLUID-BED DRI/HBI</b>										
C-17	CIRCORED/HBI/EAF WITH ONLY RECYCLE SCRAP CHARGE TO EAF	\$37.95		\$7.58	\$78.22			\$55.60	\$5.92	\$185.27
C-18	CIRCOFER/HBI/SAF/EAF WITH ONLY RECYCLE SCRAP CHARGE TO EAF	\$36.80		\$15.08	\$51.00	\$38.68		\$40.33	\$6.66	\$188.55
C-19	FINMET/HBI/EAF WITH ONLY RECYCLE SCRAP CHARGE TO EAF	\$37.11		\$6.77	\$79.72			\$55.60	\$5.92	\$185.12
C-20a	GENERIC IRON CARBIDE/EAF RECYCLE SCRAP CHARGE TO EAF	\$36.05			\$81.34			\$54.53	\$5.92	\$177.84
C-20b	GENERIC IRON CARBIDE/SAF/EAF 60% SCRAP CHARGE TO EAF	\$14.42			\$32.54	\$17.01	\$89.25	\$45.52	\$6.66	\$205.40
<b>OTHER PROCESSES</b>										
C-21	SL/RN ROTARY KILN WITH ONLY RECYCLE SCRAP CHARGE TO EAF	\$28.73		\$49.07	\$20.31		\$16.53	\$61.73	\$9.09	\$185.46

---

## Section 3: Ironmaking Process Discussion and Grouping

### 3.1 Processes Considered and Initial Screening

The goal of the Alternative Ironmaking Process Study was to analyze a number of different ironmaking processes in a manner to evaluate their individual potential and to provide a consistent method for relative comparison. To compare the processes given the diverse nature of the types of iron unit products that were produced and differing percentages of those iron units being utilized to produce steel, it was decided to normalize each ironmaking process by integrating it with an Electric Arc Furnace (EAF) steelmaking scenario. A net production of 1.0 MM tonnes of Refined Liquid Steel (as produced by the EAF/LRF process) was the normalized final product on which the processes were compared. In this fashion various proportions of the iron production and various states of the iron (e.g. as hot metal, cold pig iron, direct reduced iron, etc.) could be compared utilizing a typical commercial scenario.

It was the intent from the outset of the Study to compare proven commercial process with evolving or "first-of-a-kind" technologies not yet commercially proven. In addition, conceptual processes or those being researched and developed into potentially viable technologies were also given consideration in the Study. An initial screening and judgmental evaluation of the processes and potential production scenarios resulted in approximately 20 Ironmaking production scenarios that were selected to be evaluated and compared in more detail.

The heat and mass balance modeling techniques discussed in Section 2-2 were utilized to develop bases for Capital and Operating Cost estimates, definition of cumulative emissions as represented by carbon gas (as CO<sub>2</sub>) and cumulative electrical power consumption. To combine the impacts of Capital and Operating Costs, a simple Internal Rate of Return (IRR) calculation was made for each of the processes. These and other variables relating to the Iron and Steelmaking production scenarios for each process were used as a basis for comparison and ranking.

---

### 3-1.1 Processes Considered in Initial Screening

<u>TYPE</u>	<u>STATE OF DEVELOPMENT</u>
SHAFT FURNACE	
• Blast Furnace	Proven Commercial
• Corex	Proven Commercial
• Midrex	Proven Commercial
• Hylsa (HYLIII, HYLIVM, etc.)	Proven Commercial
• Tecored	Pilot Scale
ROTARY KILN	
• SL/RN	Proven Commercial
ROTARY HEARTH	
• Redsmelt	Semi-Commercial
• Fastmet/Fastmelt	Pilot Scale
• Itmk3	Pilot Scale
• Inmetco	Semi-Commercial
• Iron Dynamics	Semi-Commercial
• MauMee	Semi-Commercial
FLUIDIZED BED	
• Finmet	Semi-Commercial
• Circored	Semi-Commercial
• Circofer	Semi-Pilot Component
• Nucor/ICH (Single-Stage IC)	Demonstration
• Qualitech/Kawasaki (Two-Stage IC)	Demonstration
• Procedyne (Multi-stage IC)	Semi-Pilot Component
OTHER (REACTOR ETC.)	
• Hismelt	Pilot Scale
• Dios	Pilot Scale
• Romelt	Pilot Scale
• Gridsmelter	Semi-Pilot Component
• Comet	Semi-Pilot Component
• PlasmaRed	Semi-Pilot Component
• AISI/Cyclone	Pilot Scale



---

The distinction above is:

- Proven Commercial                      The process is operating commercially in more than one economically-viable installation.
- Semi-Commercial                      The process is undergoing startup in a first-of-a-kind commercial scale installation or is still in process demonstration phase.
- Demonstration                      The process has operated at a first-of-a-kind commercial scale, but is no longer being operated.
- Pilot Scale                      The process has been operated at an integrated pilot scale.
- Semi-Pilot Component                      Parts of the process have been operated at a pilot scale.

In an initial evaluation and screening of the above processes, it was determined that some of the processes could not be definitively compared since not enough open information was available to close an energy and mass balance. Sparse data that were available for such processes, in some cases, did not indicate that there was a sufficient incentive to attempt to evaluate in detail.

In other cases, the Ironmaking processes were not at a sufficient stage of development or had a potential economic advantage to warrant further consideration. An example of this was the production of Direct Reduced Iron at a high carbon content (i.e. at 2.5 wt.% C versus 1.0 wt.% C) in the shaft furnace (Midrex or Hylsa) processes. Changes in kinetics and reduction gas composition requirements to achieve the higher-carbon DRI product (some as iron carbide) did not indicate that there was a significant advantage over the lower Carbon DRI product when used for EAF/LRF steelmaking.

In some cases, in particular the rotary hearth, oxygen reactor types and iron carbide processes, the Ironmaking processes of several Vendors were sufficiently similar as to not warrant separate treatment. Therefore, a typical Ironmaking process or a generic process was selected for the comparative evaluation.

---

It should be noted that a number of Oxygen Reactor-based processes have been tested and are under investigation. There were typically not enough detailed operating and/or complete process descriptions available to define these processes with enough detail to be at the same level of precision as the other, more-conventional, Ironmaking processes. The Hismelt process was selected for further evaluation and is deemed to be typical of this group. Others may have better, or less favorable, attributes, but could not be further explored or compared with the other Ironmaking processes.

A number of Plasma-based processes were also initially considered. The Author has personal process development experience in Direct Plasma ore reduction and/or melting processes. Lockwood Greene has also had confidential discussions with Plasma-Met Technology; thus there is an internal base of information on such processes. However, the extraordinary electrical power requirements for these processes and low efficiency (not rigorously defined, but estimated from available data) did not indicate any competitive potential. As a group, these were not selected for further definition or evaluation.

An abridged list of Ironmaking process scenarios for further evaluation and comparison was selected. These are the ones for which the detailed comparisons and ranking analyses were done (See Section 4).

### **3-1.2 Process Scenarios Selected:**

#### **SHAFT FURNACE DRI – VARIATION IN CARBON AND SCRAP CHARGE**

- Base Case: 100% Shaft Furnace DRI (i.e. Midrex) Charge to EAF, 1.0 wt.% DRI (Recycle Steel Scrap Only)
- 100% Steel Scrap Charge to EAF (For Reference Only)
- 30% Shaft Furnace DRI/70% Scrap Charge to EAF (a Common Industry Practice), 1.0 wt.% DRI Carbon
- Hylsa Shaft Furnace Without Reformer (HYL IVM), Hot DRI Charge to EAF

---

## **HOT METAL VARIATIONS**

- 30% Blast Furnace Hot Metal/70% Scrap Charge to EAF, Co-Product Coke
- Mini Blast Furnace Comparison @ 30% H.M./70% Scrap Charge to EAF, Co-Product Coke
- 30% Blast Furnace Hot Metal/70% Scrap Charge to EAF, Continuous Non-Recovery Coke with Co-Generation of Electric Power
- 30% Cold Pig Iron/70% Scrap Charge to EAF, 4.5% Carbon
- 30% Tecnoled Hot Metal/70% Scrap Charge to EAF, 4.5% Carbon H.M. With Integral Co-Generation of Electrical Power
- 30% Tecnoled Hot Metal/70% Scrap Charge to EAF, 4.5% Carbon H.M. Without Co-Generation of Electrical Power
- Corex (VAI)/Midrex with 60% Hot Metal and 40% DRI Charge to EAF
- HiSmelt (ISCON) with 34.5% Hot Metal Charge to EAF

## **ROTARY HEARTH FURNACES**

- Redsmelt (Mannesmann) Hot Metal With Only Recycle Scrap Charge to EAF
- MauMee R&E Briquette DRI/EAF With Only Recycle Scrap Charge to EAF
- ITMK3 (Midrex RHF) to EAF With Only Recycle Scrap Charge to EAF

## **FLUID-BED DRI/HBI**

- Circored (Lurgi)/HBI/EAF With Only Recycle Scrap Charge to
- Circofer (Lurgi)/HBI/SAF/EAF With Only Recycle Scrap Charge to EAF
- Finmet (VAI)/HBI/EAF With Only Recycle Scrap Charge to EAF
- Generic Iron Carbide (ICH)/EAF With Only Recycle Scrap to EAF (Represents Nucor/ICH, Qualitech/Kawasaki, Procedyne Processes)
- 40% Iron Carbide Charge/60% Scrap to EAF (Believed to be Maximum Practical or Feasible Charge Ratio)

---

## OTHER PROCESSES

- SL/RN (Stelco-Lurgi) Rotary Kiln With Only Recycle Scrap Charge to EAF

### 3-2: Process Descriptions and Flow Diagrams

The following are brief descriptions and pictorial Process Flow Diagrams of Selected Ironmaking Processes:

#### 3-2.1 SHAFT FURNACE PROCESSES:

##### Blast Furnace

###### PROCESS BACKGROUND:

The blast furnace process is based upon a moving bed reduction furnace which reduces iron ore with coke and limestone. Reduction is carried out at typical reduction temperatures. The process produces liquid pig iron.

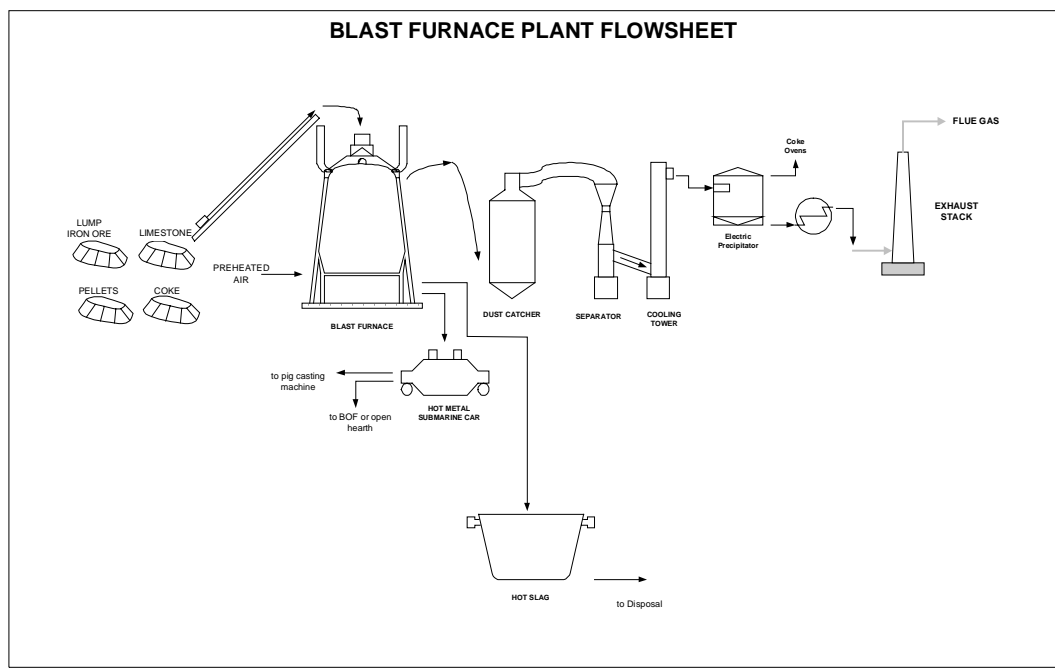
###### PROCESS DESCRIPTION:

The blast furnace process consists of weighing of the burden, charging of the blast furnace, hot product dispersal from the blast furnace and offgas cleanup system. The blast furnace is a tall shaft-type furnace with a vertical stack superimposed over a crucible-like hearth. Iron bearing materials (iron ore, sinter, pellets, mill scale, steelmaking slag, scrap, etc.), coke and flux (limestone and dolomite) are charged into the top of the shaft. A blast of heated air and also, in most cases, a gaseous, liquid or powdered fuel are introduced through openings at the bottom of the shaft just above the hearth crucible. The heated air burns the injected fuel and most of the coke charged in from the top to produce the heat required by the process and to provide reducing gas that removes oxygen from the ore. The reduced iron melts and runs down to the bottom of the hearth. The flux combines with the impurities in the ore to produce a slag which also melts and accumulates on top of the liquid iron in the hearth. The total furnace residence time is about 6 to 8 hours. The hot metal produced is sent to a steelmaking shop or a pig-casting machine. The slag goes to a water-spray granulator, a cry slag pit or a slag dump. The gas from the top of the furnace goes through the gas cleaning system, and then a portion goes to fire the hot blast stoves with the balance being used in other parts of the plant. The dust is removed from the

gas in the cleaning system and goes to the sinter plant to be agglomerated for recycling back into the blast furnace.

#### PROCESS ADVANTAGES

Proven performance  
Raw material flexibility



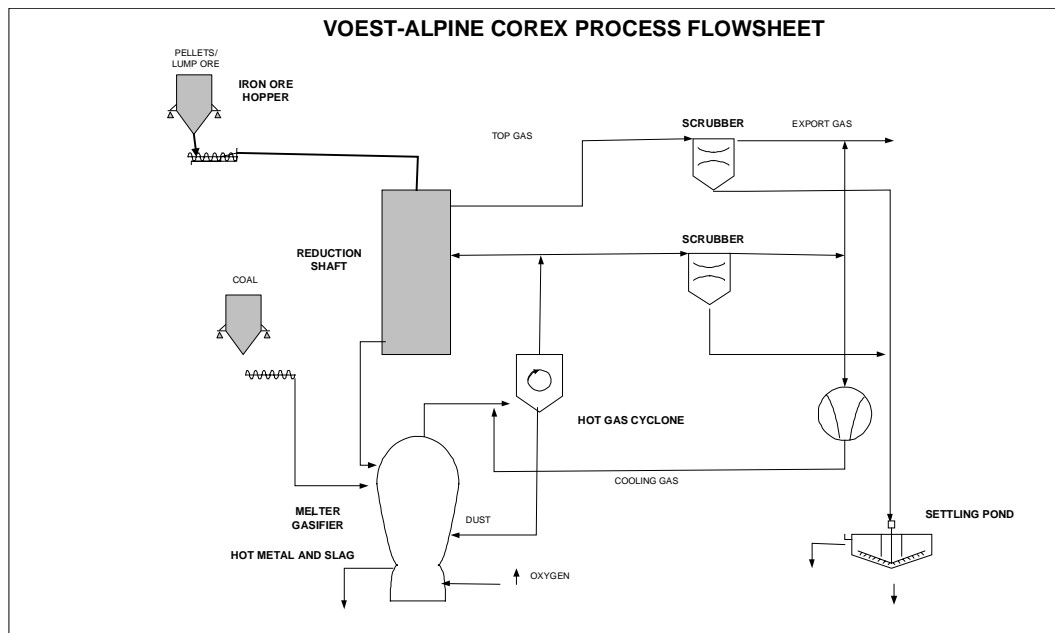
#### Corex

The iron oxide feed to a Corex reduction shaft is in the form of lump ore or pellets. Non-coking coal is used in the Corex process as the strength of coke needed in the cohesive zone of the blast furnace to provide sufficient permeability to the bed is not required. All other coke functions such as fuel supply, basis for the reduction gas generation and carburization of the hot metal can be fulfilled as well by non-coking coal. Similar to the blast furnace process, the reduction gas moves in counter flow to the descending burden in the reduction shaft. Then, the reduced iron is discharged from the reduction shaft by screw conveyors and transported via feed legs into the melter gasifier. The gas containing mainly of CO and H<sub>2</sub>, which is produced by the gasification of coal with pure O<sub>2</sub> leaves the melter gasifier at temperatures between 1000 and 1050C. Undesirable products of the coal

gasification such as tar, phenols, etc. are destroyed and not released to the atmosphere. The gas is cooled to 800-850C and cleaned from dust particles. After reduction of the iron ore in the reduction shaft, the top gas is cooled and cleaned to obtain high caloric export gas. The main product, the hot metal can be further treated in either EAF or BOF or can be cast and sold as pig iron.

## PROCESS ADVANTAGES

Use of low cost non-coking coal



## Midrex Shaft Furnace

### PROCESS BACKGROUND:

The Midrex™ Direct Reduction process is based upon a low pressure, moving bed shaft furnace where the reducing gas moves counter-current to the lump iron oxide ore or iron oxide pellet solids in the bed. The reducing gas (from 10-20% CO and 80-90% H<sub>2</sub>) is produced from natural gas using Midrex's CO<sub>2</sub> reforming process and their proprietary catalyst (instead of steam reforming).

---

A single reformer is utilized instead of a reformer/heater combination. The reformed gas does not need to be cooled before introduction to the process. There is also no need for a separate CO<sub>2</sub> removal system.

The process can produce cold or hot DRI as well as HBI for subsequent use as a scrap substitute feed to a steelmaking melting furnace (SAF, EAF or oxygen steelmaking process).

Over 50 Midrex™ Modules have been built worldwide since 1969. They have supplied over 60% of the worlds DRI since 1989.

#### PROCESS DESCRIPTION:

The iron oxide feed to a Midrex® shaft furnace can be in the form of pellets, lump ore or a mixture of the two (in 0 to 100% proportions). The solid feed is discharged into a feed hopper on top of a proportioning hopper that evenly distributes the solids into the shaft furnace.

A dynamic seal leg keeps the reducing gas inside the furnace. The shaft furnace operates at low pressure, under 1 bar gauge, which allows dynamic seals to be used on the furnace inlet and discharge. The iron ore burden in the shaft furnace is first heated, then reduced by the upward flowing, counter-current reducing gas that is injected through tuyeres located in a bustle distributor at the bottom of the cylindrical section of the shaft. The ore is reduced to a metallization typically in the range of 93% to 94% by the time it reaches the bustle area.

Below the bustle area, it goes through a transition zone (with design to reduce agglomeration or lumping) and then reaches the lower conical section of the furnace. Lower carbon reduced iron (<1.5% C) is cooled using a circulating stream of cooled exhaust gas that is introduced in the conical section for cold DRI discharge. Higher carbon DRI (up to 4.0% C) can be produced by introduction of natural gas into this cooling gas. It readily reacts (and cracks) with the highly reactive metallic DRI.

For hot discharge of DRI to be used for hot charging of EAF's (i.e. Midrex's Hotlink™ Process) or for feed to hot briquetting presses (to produce HBI), the lower part of the furnace is modified to allow handling of hot burden.

The Midrex gas generation system consists of a CO<sub>2</sub> reformer using their own catalyst. The feed to the reformer is a mixture of process gas recycled from the furnace and makeup natural gas. The top gas leaving the shaft furnace at a temperature of 400 to 450C is cooled and dust is removed in a top gas scrubber. About two-thirds of the gas is recycled back to the process (process gas) and the rest is used as a fuel. The process gas is compressed, mixed with natural gas and is preheated in the reformer recuperator before entering the tubes of the reformer.

The reformed gas comprising of mostly CO and H<sub>2</sub> exits the reformer at about 850 °C and passes through collection headers to the reformed gas line. The ratio of H<sub>2</sub> to CO is controlled at about 1.5 to 1.8, and reducing quality at 11 to 12 for best operation.

#### PROCESS ADVANTAGES:

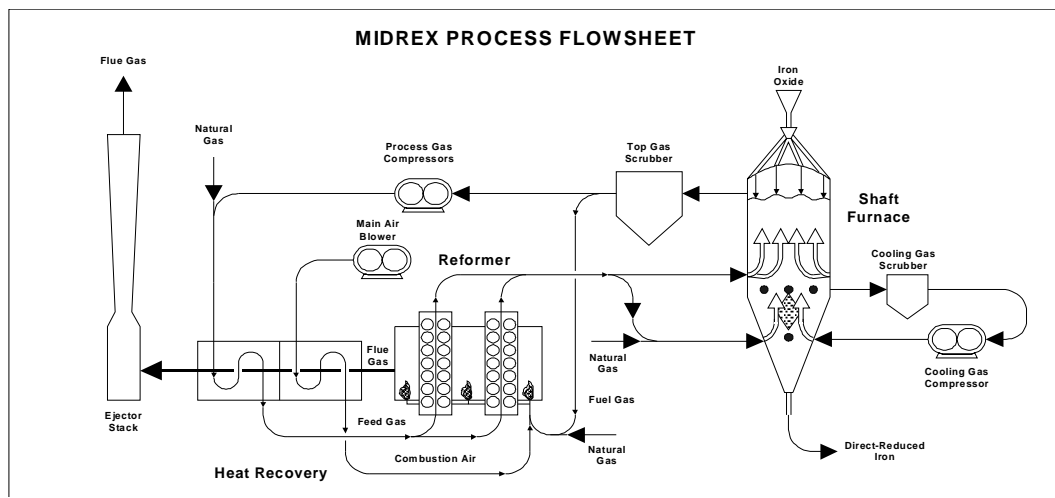
World-wide commercial use

Proven performance

“Relatively-forgiving” operation

Raw material flexibility

CO<sub>2</sub> reformer eliminates need for steam system, reformed gas quench, reducing gas heating and CO<sub>2</sub> removal system.





---

## HYLSA IVM

### PROCESS BACKGROUND:

The Hylsa 4M process is based on a moving bed shaft furnace (similar to HYL III process but without a reformer) which reduces iron ore pellets and lump ore, and operates at typical reduction temperatures and intermediate reduction pressures. This process requires no reformer to generate the reducing gas as the reforming of the natural gas takes place inside the reduction reactor using the metallic iron of the DRI product as the catalyst. The process can produce cold/hot DRI as well as HBI.

### PROCESS DESCRIPTION:

As before, the iron oxide feed to a Hylsa 4M furnace can be pellets, lump, or a mixture of the two (from 0 to 100% of either). HYL divides the process into three primary units: Reduction system, DRI handling system and External cooling system.

The HYL 4M reactor operates at similar conditions to the other Hylsa reactors (e.g. HYL III, etc.). The reactor has a cylindrical upper section where reduction and reforming reactions take place. The lower part is conical with a rotary valve at the end to control the flow of solids discharging the reactor.

The starting point of the reduction circuit is the fresh stream of natural gas that is used as a makeup for the process. This natural gas (desulfurization is not necessary, but is optional) is mixed with recycled gas and fed to a humidifier, where the humidity of the total stream of reducing gas is controlled to adjust the carbon deposition rate on the DRI at the bottom of the reactor.

The reducing gas goes to the top gas heat recuperator, where sensible heat is recovered from the reactor top gas. Then the preheated gas goes to a gas heater where its temperature is increased to above 900 °C. In the transfer line to the reactor, O<sub>2</sub> is injected in order to have some partial combustion of the reducing gas to increase its temperature to above 1020 °C. This gas, upon introduction into the bottom of the HYL reactor, flows upward into the reduction zone countercurrent to the moving bed of solids. In the lower part of the reduction zone, insitu reforming reactions are carried when this

hot gas contacts the metallic DRI product. The metallic iron in the DRI acts as a catalyst for the reforming reactions. In addition, this occurs in parallel with the final stage of reduction of the iron ore. As a result some of the DRI reacts with the carbon and is carburized (to  $\text{FeC}_3$ ) and there is some excess free carbon.

#### PROCESS ADVANTAGES:

Proven equipment performance (uses HYL II and HYL III reactor technology)

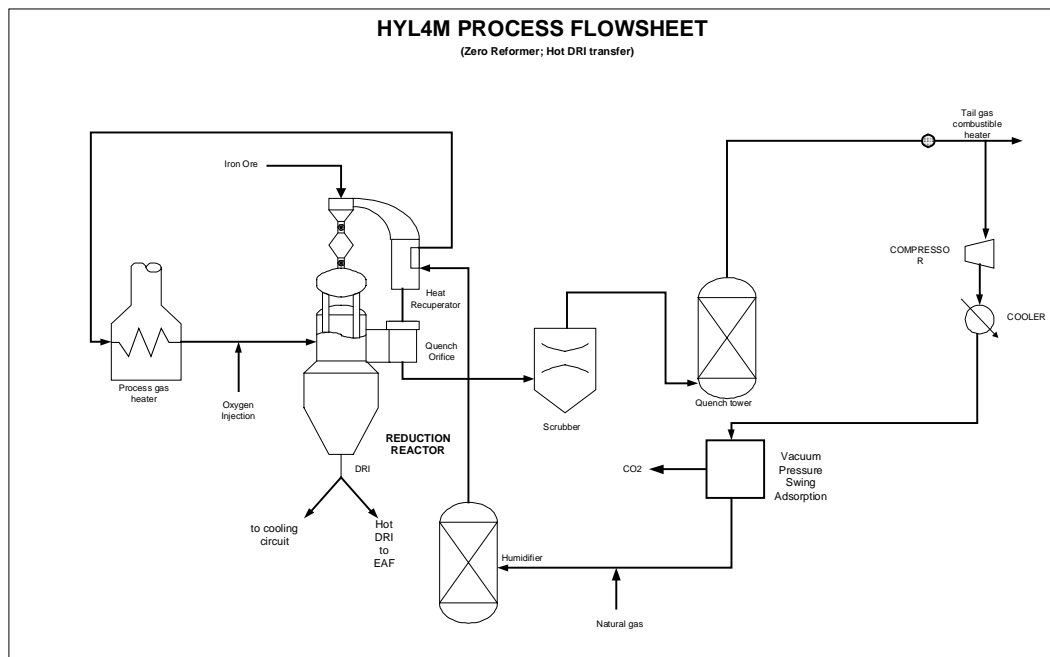
Raw material flexibility

Not sensitive to S in natural gas or ore

No reformer – lower Capital costs

High-energy efficiency (87% in comparison to 70% for most efficient other DRI plants).

Hylsa claims lower overall operating costs (to be confirmed)



---

## Tecnored

### PROCESS BACKGROUND:

The Tecnored process is based upon a low pressure moving bed reduction furnace which reduces pellets made out of iron ore fines with cement and coke fines. Reduction is carried out at typical reduction temperatures. The process produces liquid pig iron.

### PROCESS DESCRIPTION:

The Technored process consists of pelletizing of the iron ore fines with cement and coke fines. The pellet size is controlled for the optimum reaction in the reduction furnace. The pellets are cured and dried at 200C and fed to the top of the furnace. The furnace internal pressure is about 3.5 to 5.2 psig. The total furnace residence time is 30 to 40 minutes against 6 to 8 hours in blast furnace.

Lump coke is fed into side feeders in the furnace below the hot pellet area. Hot blast air at about 1550C is blown in through tuyeres located in the side of the furnace to provide combustion air for the coke. A small amount of furnace gas is allowed to flow through the side feeders to use for pet coke drying and preheating. Cold blast air is blown in at a higher point to promote post combustion of CO in the upper shaft. The use of coke with sulfur (pet coke) necessitates an elaborate furnace clean-up system in order to meet environmental regulations.

The pig iron produced is tapped into a ladle on a ladle car, which can tilt the ladle for deslagging. The liquid iron is desulfurized in the ladle, and slag raked into a slag pot.

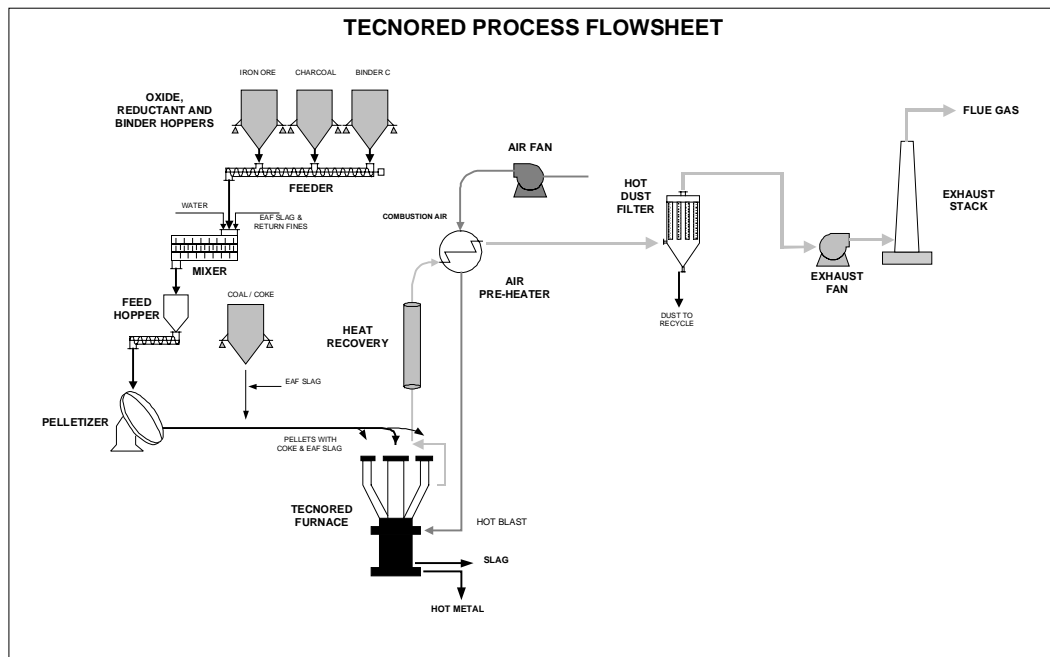
## PROCESS ADVANTAGES

Low cost raw materials

Low melting costs using low cost fuels to reduce electric power and electrode cost.

High productivity and energy efficiency in the furnace

Full metallization (up to 99%)



---

### 3-2.2 ROTARY KILN

#### SL/RN

##### PROCESS BACKGROUND:

The SL/RN process is a kiln based process that uses lump ore, pellets, beach sand or ilmenite ore and solid carbon to produce hot or cold DRI. The process operates at high temperature and atmospheric pressure. This is the most widely used coal based direct reduction process.

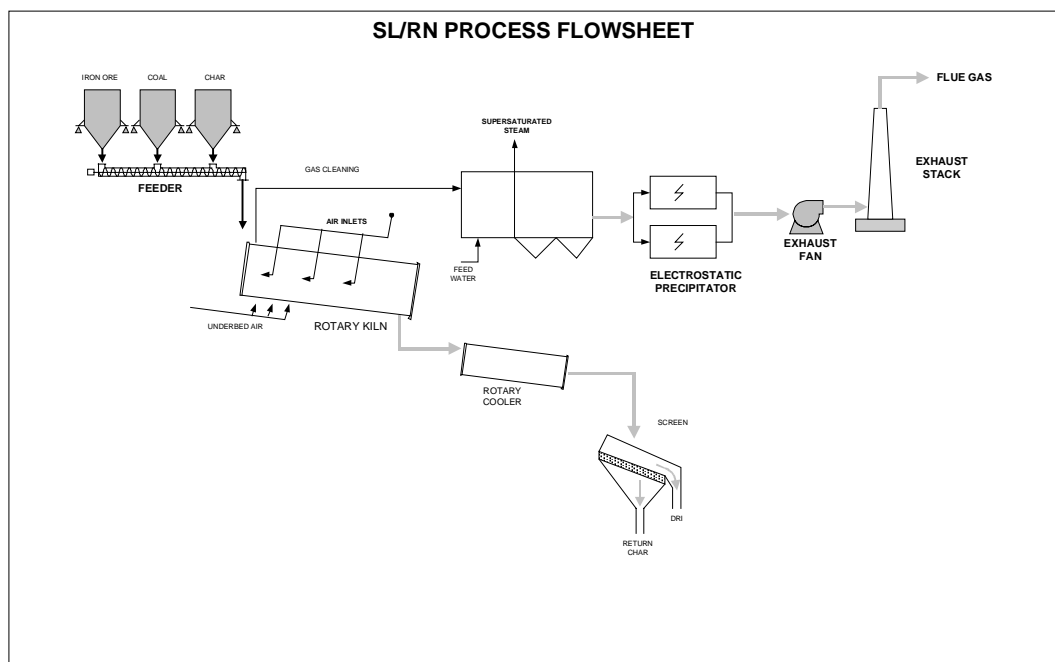
##### PROCESS DESCRIPTION:

The iron oxide feed to a SL/RN kiln is in the form of lump or pellet iron ore, reductant (low-cost non-coking coal) and limestone or dolomite (to absorb sulfur from high sulfur reductant). The rotary kiln is inclined downward from the feed (elevated end) to the discharge end. The discharge end is provided with a burner to be used for startup or to inject reductant. Typical retention times are around 10 hours. The kiln is divided into two process regions; preheat and reduction. In the preheat section, the charge is heated to about 1000C, free moisture is first driven off and reduction to FeO occurs. As the reductant is heated, volatile components are released and part of the gases are burned in the freeboard above the bed by the air injected into the kiln. This combustion transfers heat to the charge directly by radiation, and also by conductive heat transfer from the kiln lining, which is first exposed to the flame and heated before contacting the charge. The charge then passes into the metallization or reduction zone where the temperature is maintained at about 1000C to 1100C, depending upon the type of charge used. The final metallization is about 93% and carbon content about 0.1 to 0.2%. The product DRI can be discharged hot or cold.

The combustion off-gases from the kiln contain char particles and combustible gases. These are burned off in a afterburner and the offgas then passes through an evaporative cooler and an electrostatic precipitator and vented to the atmosphere.

## PROCESS ADVANTAGES

Use of any iron bearing material  
Wide variety of reductants  
Proven DRI technology  
Economic production of DRI



### 3-2.3 Rotary Hearth

#### Redsmelt

#### PROCESS BACKGROUND:

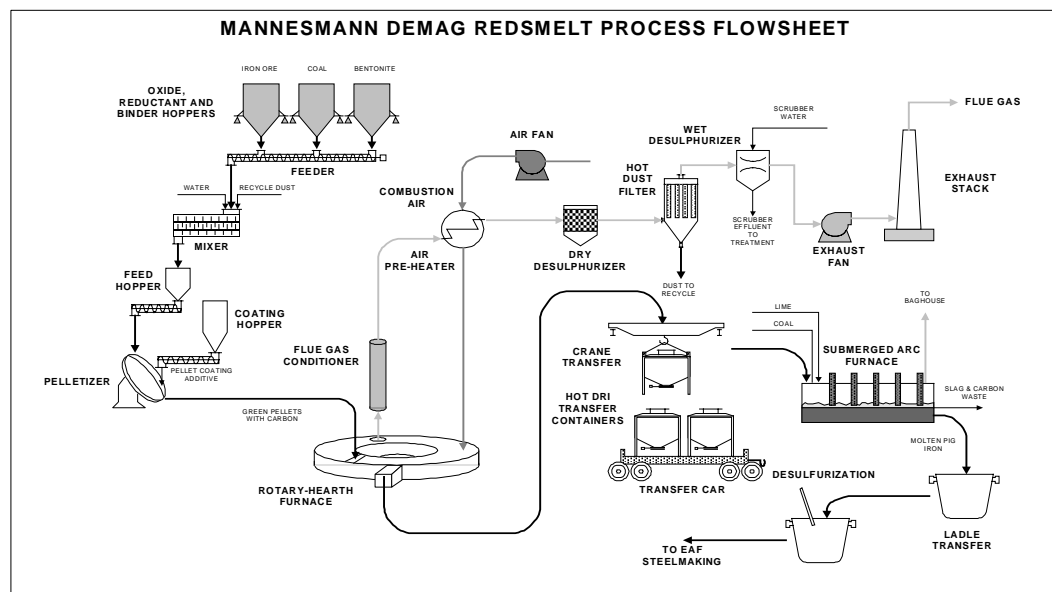
The Redsmelt process is based upon a rotary hearth furnace which reduces green pellets made out of iron ore, reductant fines and binders to produce hot, metallized DRI that is charged to a Submerged Arc Furnace. The process operates at high temperature and atmospheric pressure.

## PROCESS DESCRIPTION:

The iron oxide feed to a Redsmelt furnace is in the form of green pellets made of fine iron ore, reductant and binders. Binders are given to the green pellets sufficient mechanical strength to support the handling shocks downstream. Pellets are screened on a roller-type screen to a size between 8 to 16 mm. Under and oversize materials are recirculated to feed the pelletizing disks. Pellets are then distributed onto the RHF in a layer up to 30 kg/m<sup>2</sup>. While traveling throughout the furnace in 12 to 18 minutes, pellets are heated up to 1370°C. Drying of the pellets, coal devolatilization and iron oxide reduction takes place during the heating process. The intimate contact between iron oxide and carbon at a very high temperature results in a very fast reaction rate. To prevent reoxidation of metallized iron the final zones of the furnace are operated in sub-stoichiometric atmosphere. The hot DRI product is then fed to the submerged arc furnace (SAF) for smelting into Hot metal and slag.

## PROCESS ADVANTAGES

- Iron ore fines as raw material
- Wide variety of solid reductants
- Less reduction time (12 to 18 minutes)
- Proven equipment usage



---

## **Fastmet/Fastmelt**

### PROCESS BACKGROUND:

The FastMet process is based upon a rotary hearth furnace which reduces briquettes made out of iron ore fines, waste iron bearing materials and pulverized coal to produce hot, metallized DRI that can be directly charged to a specially designed electric melter (FASTMELT) or HBI.

### PROCESS DESCRIPTION:

The iron oxide feed to a FastMet furnace is in the form of dried greenballs made of iron ore and coal. They are continuously fed to the RHF by means of a loss-in-weight vibrating pan feed system. After introduction, the greenballs are heated in 3 burner/ reaction zones; all fired by side-wall mounted burners. Zone 1 has three burners, Zone 2 has five burners and Zone 3 has two burners. All burners are designed for air/natural gas or oxygen enriched air/natural gas combustion. A water cooled chill plate is positioned after Zone 3 for cooling of the hot DRI product to 1000-1200C prior to discharge from the RHF. The hot DRI product can either be collected in N<sub>2</sub> purged transfer cans, or directly fed to the electric furnace for melting. The RHF operates under a slight negative pressure, and sealed by a water seal trough.

The DRI melter is a custom design single phase AC electric arc furnace type melter that has a stationary hearth and a water cooling roof. It produces carbon containing molten iron (FASTIRON) from a charge of 100% hot DRI continuously fed from the RHF.



## PROCESS ADVANTAGES

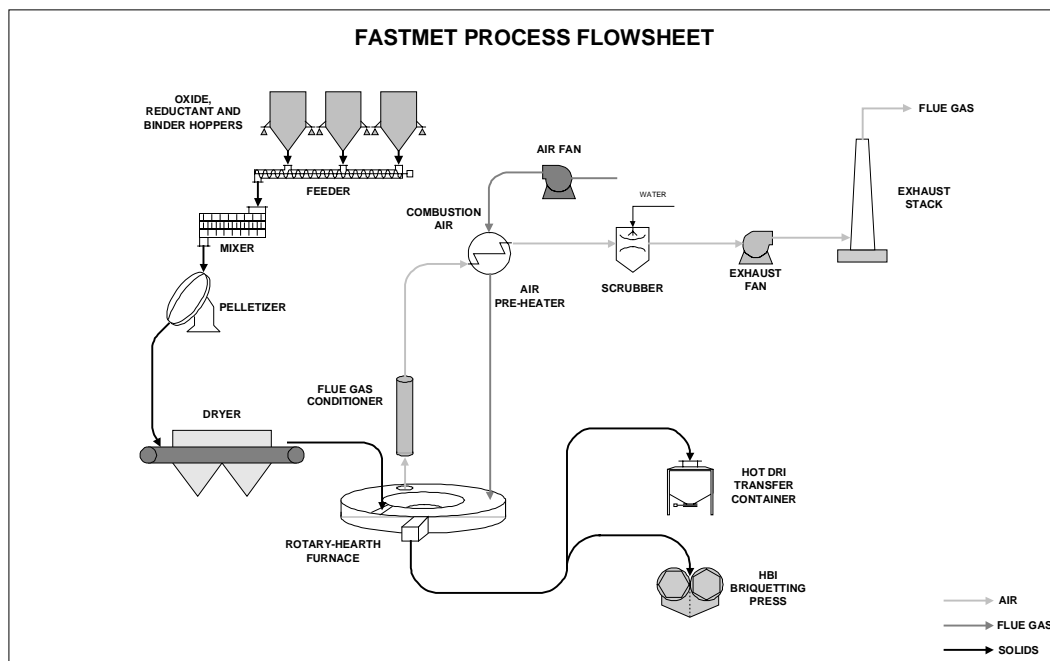
Iron ore fines as raw material

Wide variety of solid reductants

Less reduction time (6-12 minutes)

Lower capital investment costs than NG based DR processes

Proven equipment usage



## ITMK3

### PROCESS BACKGROUND:

The ITmk3 process is based upon a rotary hearth furnace similar to a FASTMET furnace which reduces dried green pellets made out of iron ore, reductant fines and binders to produce hot, metallized DRI that is charged to a Melter which separates liquid metal from liquid slag in a short time. The process operates at high temperature and atmospheric pressure.

---

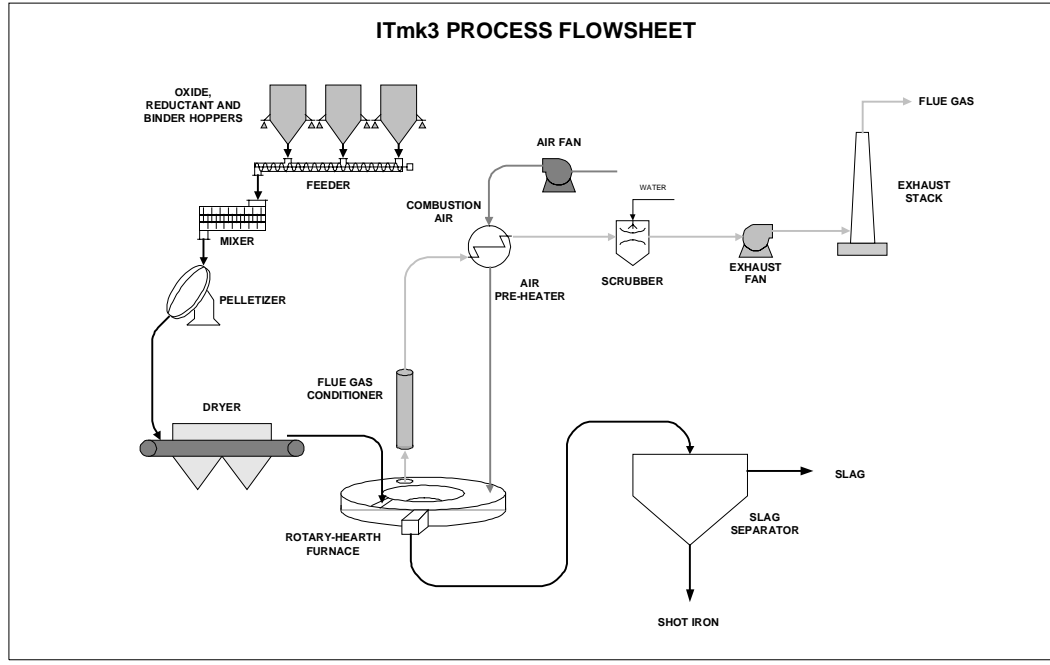
## PROCESS DESCRIPTION:

The iron oxide feed to a ITmk3 furnace is in the form of dried green pellets made of fine iron ore, reductant and binders. Binders are to give to the pellets sufficient mechanical strength to support the handling shocks downstream. Pellets are dried and screened for 17 to 19 mm greenball diameter. Undersize and oversize materials are recirculated to feed the pelletizing disks. Pellets are then distributed onto the RHF. While traveling throughout the furnace, pellets are heated up to 1350C. Drying of the pellets, coal devolatilization and iron oxide reduction takes place during the heating process.

The intimate contact between iron oxide and carbon at a very high temperature results in a very fast reaction rate. Heating of the gangue and ash components also occurs and leads to softening and subsequent initiation of slag droplet coalescence. Often a hollow, highly metalized iron shell is formed, and at the bottom of the hollow is a bead of melted slag. The hot product is then fed to the Melter for complete separation of Hot metal or the cold iron shots (iron nuggets) from slag. Further heating in the melter results in the formation of molten iron droplets, collapse of the iron shell structure followed by coalescence of iron droplets into a nugget of molten iron which is completely separated from the slag.

## PROCESS ADVANTAGES

- Iron ore fines as raw material
- Wide variety of solid reductants
- Less reduction time
- Complete separation of hot metal from slag



## Inmetco Process

### PROCESS BACKGROUND:

The Inmetco process is based upon a rotary hearth furnace which reduces briquettes made out of iron ore fines, waste iron bearing materials and pulverized coal to produce hot, metallized DRI that can be directly charged to an electric melter or HBI. The process operates at high temperature and atmospheric pressure.

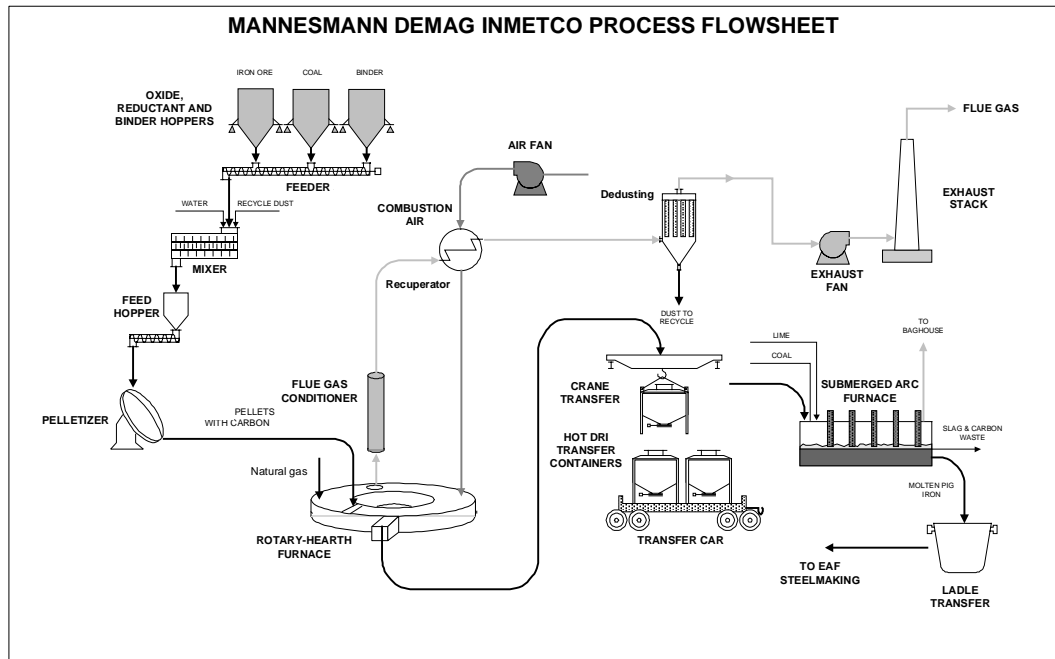
### PROCESS DESCRIPTION:

The iron oxide feed to an Inmetco furnace is in the form of disk pellets made of fine iron ore under 250um in size and fine coal or coke or char with less than 25% volatiles. They are distributed onto the RHF in a layer about 3 pellets deep by means of a pivoting belt conveyor. The process uses a quick acting binder which allows the pellets to be transported to the hearth without significant degradation. The hearth rotates continuously and the pellets are heated by burners located around the periphery of the hearth to 1250C to 1300C during a period of 10 to 15 minutes. The burners are arranged in groups, and form heating and reduction zones. The heating

zone makes about 1/3 of the hearth area and the reduction zone about 2/3. The burners are located on the inner and outer circumference. The hot DRI product can either be collected in N<sub>2</sub> purged transfer cans, or directly fed to the electric furnace for melting. The RHF operates under a slight negative pressure, and sealed by a water seal trough.

## PROCESS ADVANTAGES

- Iron ore fines as raw material
- Wide variety of solid reductants
- Less reduction time (6-12 minutes)
- Proven equipment usage



---

## Iron Dynamics

### PROCESS BACKGROUND:

The Iron Dynamics process is based upon a rotary hearth furnace which reduces a carbonaceous iron oxide charge to metallic iron solids that are charged to a SAF to complete the reduction and to melt and desulfurize the reduced iron. Melting the DRI also allows for a phase separation of the resulting liquid slag and iron.

### PROCESS DESCRIPTION:

The IDI process is composed of five process areas: raw material receiving, ore and reductant (coal) grinding and preparation, pelletizing, rotary hearth reduction and submerged arc furnace smelting. After the ore is received, it is dried to the moisture content less than 0.5% using offgas from the rotary hearth furnace. Ore is also beneficiated using magnetic separators and screens to reduce the amount of silica. It is then ground to 50% minus 200 mesh. Coal is conveyed to a coal/fluxstone pulverizer for sizing to 80% minus 200 mesh. Ground ore and coal are intensively mixed with binders and water in a mixer and fed onto disc pelletizers. Wet pellets are dried to less than 1% moisture and preheated to 150C in a circular grate dryer. The pellet charger receives the dried green balls and layers them onto the furnace hearth in 11/2 – 1 in. thick layers.

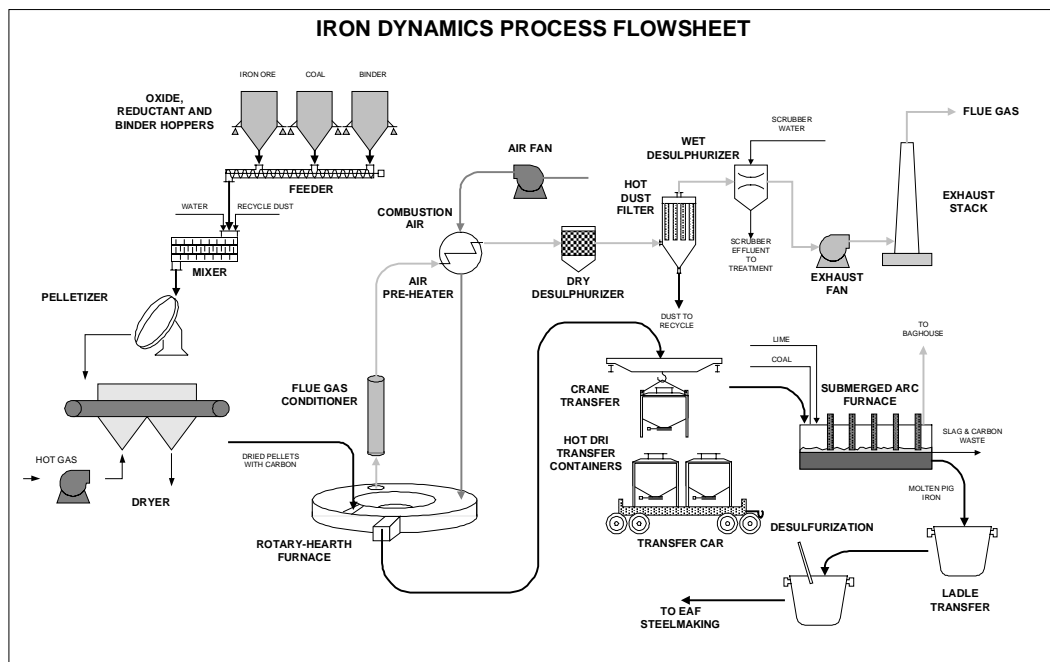
The natural gas fired rotary hearth furnace has eight reaction zones. Temperature, gas flow and gas composition are controlled to provide the required conditions in each zone to properly heat, reduce and protect the pellets. The DRI at the discharge of the furnace has about 85% metallization.

An additive facility introduces flux, coke, silica or other materials to the DRI transport bottles to control slag chemistry in the submerged arc furnace. The offgas system removes heat, dust, sulfur dioxide and nitrous dioxides from the flue gas. An afterburner combusts any remaining CO in the offgas water-cooled duct. The gas is cooled and the Nox removed in the primary cooler. Offgas is used to preheat combustion air and supply heat to the ore, coal and pellet dryers. After the pellet dryer, the gas is filtered and Sox removed prior to discharge from the stack. The DRI and the additives fall into the slag layer of the Submerged Arc Furnace by gravity where smelting

takes place. Average metallization here is about 95.8%. Slag is tapped from the furnace into slag pots and transferred to a slag processing facility.

## PROCESS ADVANTAGES

- Iron ore fines as raw material
- Wide variety of solid reductants
- Less reduction time
- Lower capital investment costs than NG based DR processes
- Proven equipment usage



## MauMee

### PROCESS BACKGROUND:

The MauMee process is based upon a rotary hearth furnace which reduces green pellets made out of waste iron oxide materials and pulverized non-metallurgical coal to produce hot, metallized (>90%) DRI. The process

---

operates at high temperature and atmospheric pressure, features a short residence time and can be used to recycle revert materials.

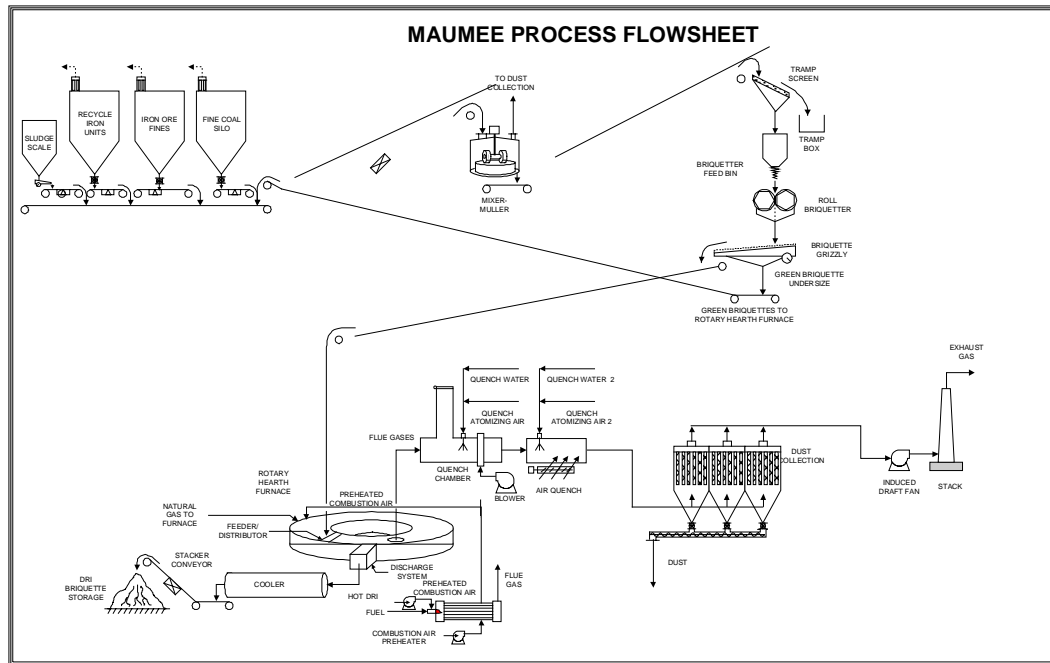
#### PROCESS DESCRIPTION:

The iron oxide feed to a MauMee furnace is in the form of green pellets/briquettes made of fine iron oxides and coal or coke that eliminates the pre-drying of the pellets. Under ideal high-temperature (2350°F) theoretical conditions, iron oxide will react with fixed carbon to form metallic iron in the briquette with the release of CO<sub>2</sub>. The theoretical ratio of fixed carbon to iron oxide is 1.5:1.

MauMee process has been formulated to produce metallic iron using a carbon-to-oxide ratio of 6:1, which results in the evolution of both CO and CO<sub>2</sub> and leaves a residual carbon level of about 4%. The key to this process is controlling the CO-to-CO<sub>2</sub> ratio to minimize reoxidation, carbon consumption and furnace residence time. While traveling throughout the furnace, pellets are heated up to 2350F. Drying of the pellets, coal devolatilization and iron oxide reduction takes place during the heating process. The intimate contact between iron oxide and carbon at a very high temperature results in a very fast reaction rate. The hot DRI product can then be supplied to the steel mill by a number of different options.

#### PROCESS ADVANTAGES

- Iron ore fines or waste iron units as raw material
- Wide variety of solid reductants
- Less reduction time
- Proven equipment usage



### 3-2.4 Fluidized Bed

#### Finmet

#### PROCESS BACKGROUND:

The Finmet process is a multiple fluidized bed process which utilizes a H<sub>2</sub> rich reducing gas produced by steam reforming. Reduction is carried out at intermediate reduction temperatures, but at a higher operating pressure than most DR processes. The process produces hot briquetted iron, HBI.

#### PROCESS DESCRIPTION:

The iron oxide feed to the Finmet process is in the form of iron fines under 12 mm in size. The fines are first dried to 0.2% moisture in a fluid bed drier at about 100C and stored in a hopper close to the reactors. In the first reactor, the oxide fines are preheated to about 550C. Then they pass through the other reducing reactors in series, where they are heated and reduced by the



reducing gas. The reactor system operates at high pressure, about 11-13 bars gauge, in order to increase the productivity.

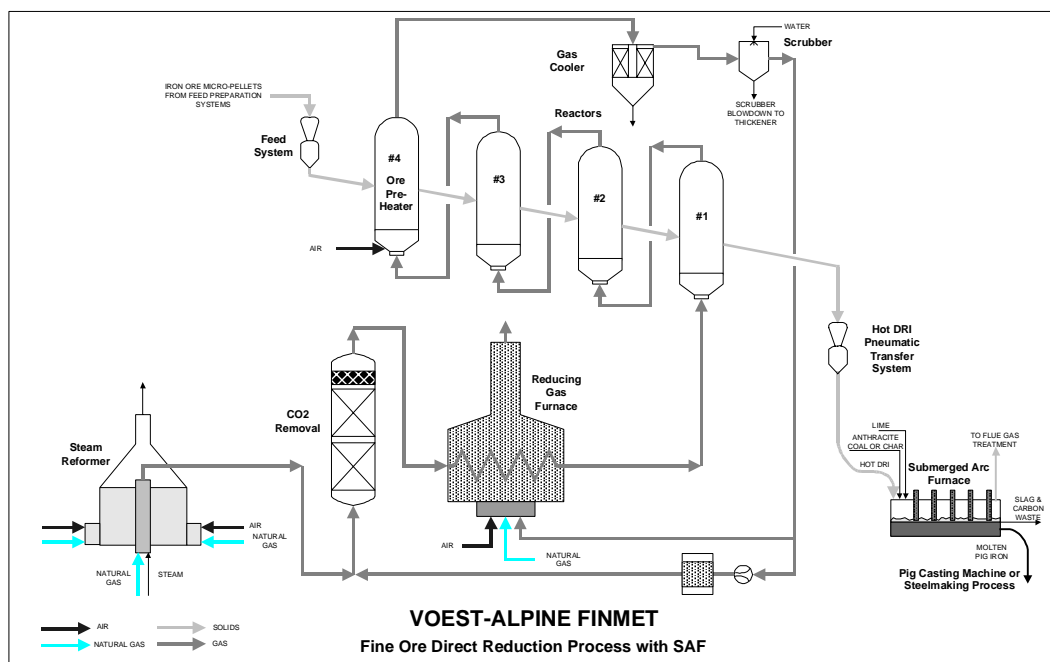
The fresh reducing gas required for the process is produced in a steam reformer with a steam to natural gas ratio of 3 to 4. The reformed gas consisting of CO and H<sub>2</sub> passes through a waste heat boiler to produce steam required for the reforming reaction. The reducing gas entering the bottommost reactor is distributed by the grid, passes through the fluid bed where reduction occurs, then exits the reactor via the cyclones, located inside the reactor vessel. Reduction temperatures range from 550C in the top reactor to about 800C in the lower one. The reduced ore exits the last reactor with a metallization of 93% and carbon in the range of 1 to 3%. The reduced fines are compacted to a density of 5 g/cc in a briquetting press.

## PROCESS ADVANTAGES

Direct use of low cost iron ore fines

Proven fluid bed technology

High process and plant flexibility through separate gas production, fines reduction and briquetting.



---

## Circored

### PROCESS BACKGROUND:

The Circored process is a two stage fluidized bed process that operates at low reducing temperatures and uses natural gas to produce reducing gas by means of reforming. The process uses ore fines that have a particle size between 1mm and 0.03mm and produces HBI.

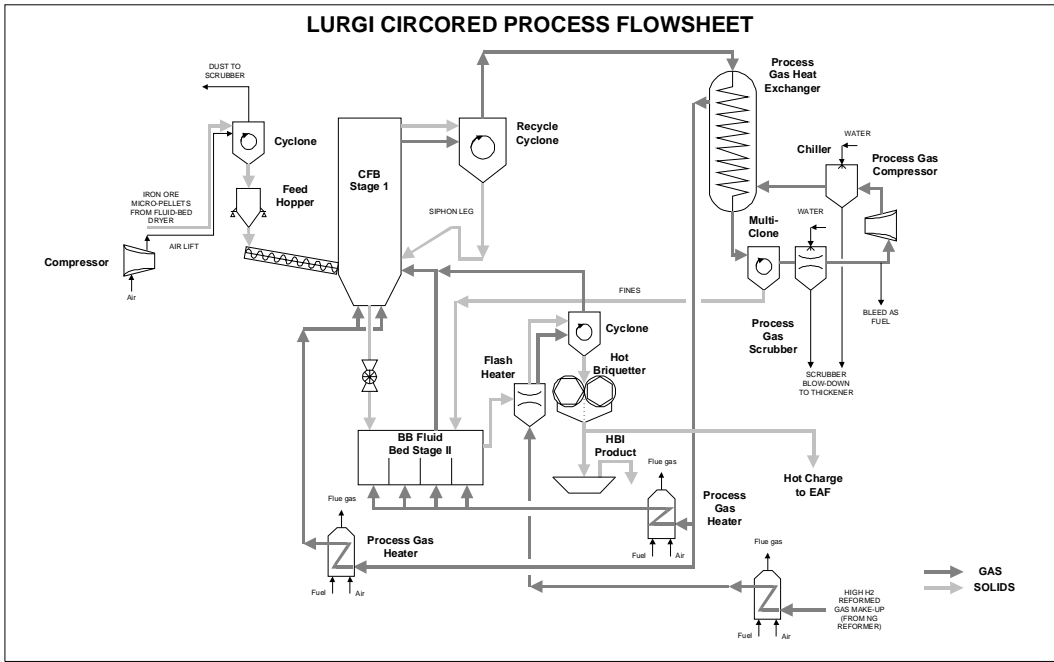
### PROCESS DESCRIPTION:

The iron ore fines are first dried and heated to about 800C in a fluid bed preheater system. The dried fines are then charged to a circulating fluidized bed (CFB). The heat required is generated by the combustion of natural gas and air that is introduced into the CFB. The fines are reduced to about 70% metallization in CFB. The process reactions are endothermic and the required energy is introduced in the form of preheated iron ore fines and process gases. The pressure in the CFB is about 4 bars and the reaction temperature is about 630C. This temperature is lower than that used for other reduction processes, and hence avoids the sticking problems that occur with high temperature fines-based processes. The fluidizing gas in the CFB is a mixture of heated process gas which enters the lower part of the CFB, and the off-gas from the second stage conventional fluidized bed reactor, Stage II Reactor, FB. The retention time in the CFB is relatively short, of the order of 15 to 20 minutes.

A portion of the partially metallized fines are withdrawn from CFB and enter the FB reactor. The FB reactor is compartmentalized into several sections, and has gas velocities in the range of 0.5 to 0.6 m/s. The fines reach a final metallization of 92 to 93% in the FB reactor. The off-gas leaving the top of the FB passes on to the CFB. The product leaves the FB reactor at about 630C, is then heated to about 680C, and briquetted.

### PROCESS ADVANTAGES

- Ability to process directly low cost fine ore
- Excellent heat and mass transfer conditions in CFB
- Low investment costs
- Low operating cost



---

## Circofer

### PROCESS BACKGROUND:

The Circofer process is a two stage fluidized bed process that uses iron ore fines and a solid carbon source such as coal to produce reducing gas. Reduction is carried out at high reduction temperatures. The process produces hot briquetted iron, HBI.

### PROCESS DESCRIPTION:

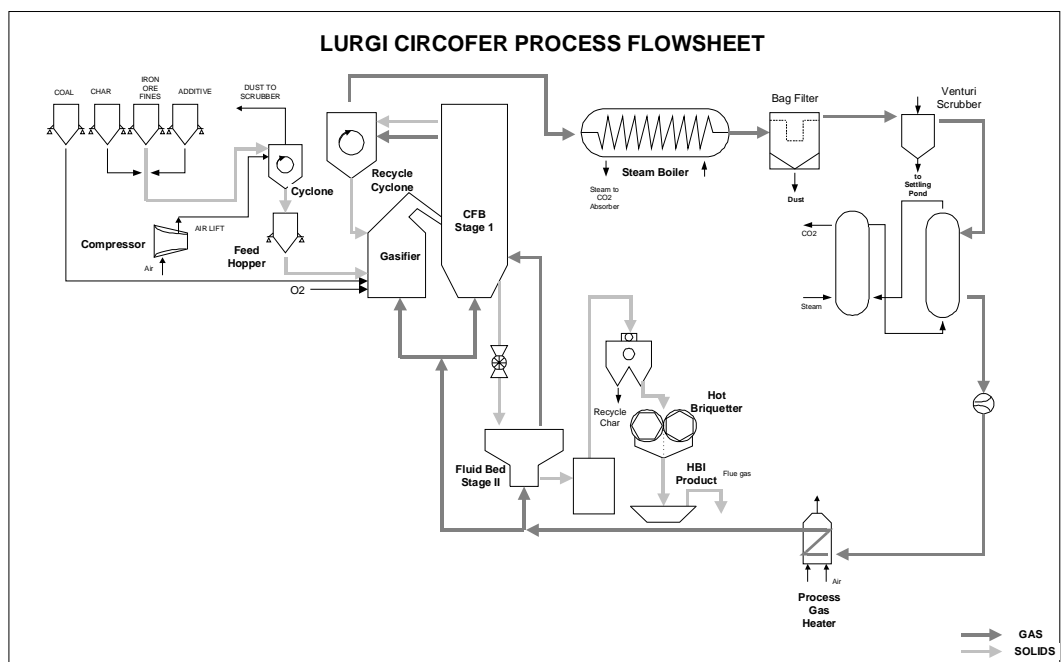
The iron oxide feed to the Circofer process is in the form of iron fines between 1mm and 0.03mm in size. The coal to be used as the energy source and reductant must have an ash softening temperature above 1500C due to operating temperature of the gasifying process. The fines, lime and char are first preheated by the hot exhaust gases. These then enter the gasifier, where O<sub>2</sub> is injected and coal is fed in from the charge hopper. The gasifier operates at about 1000C and at these conditions, the O<sub>2</sub> partially combusts the carbon contained in the coal, producing heat and a CO/CO<sub>2</sub> gas mixture. The heat produced in the gasifier heats the ore and char to process temperatures.

In the CFB, the ore fines are reduced to about 70% metallization. The fluidizing gas in the CFB is a mixture of heated recycle gas which enters the lower part of the CFB, and the offgas from the second reducer (FB) which enters further up in the CFB. The fines and char are carried out of the CFB due to the high gas velocity in the reactor, are captured by the cyclone, and returned to the CFB via the gasifier. Thus a circulation pattern is set up which allows the heat to be transferred to the CFB reactor.

Reduced solids from the CFB enter the FB reactor, which is a conventional bubbling bed. In this second reduction stage, the fines reach a final metallization of 92 to 93%. The gas leaving the top of the FB passes on to the CFB. The product from the second reducer is partially cooled, the char and ash are removed by magnetic separation, and the product is briquetted and cooled.

## PROCESS ADVANTAGES

Direct use of low cost iron ore fines  
Proven fluid bed technology  
High quality product



## Iron Carbide Processes

### PROCESS BACKGROUND:

Iron carbide ( $\text{Fe}_3\text{C}$ ) is a chemical compound of 93% iron and 7% carbon in pure form. It can be used as the only feed for BOFs and EAFs. In that role it eliminates the need for coke ovens and the blast furnace, and all the ancillary equipment for coal and lime. The Iron Carbide process is a two stage fluidized bed process that operates at a lower temperature than other DR processes. It operates at low pressures and uses steam reforming to produce the  $\text{H}_2$  which is mixed with  $\text{CH}_4$  to make the carburizing gas. It produces  $\text{Fe}_3\text{C}$  powder which contains about 6% carbon.

### PROCESS DESCRIPTION:

---

The iron oxide feed to the iron carbide process is in the form of iron ore fines in the range of 1mm to 0.1 mm. Iron ore fines are preheated in a series of cyclones and then pressurized to reactor pressure in lockhoppers, and fed to the reactor by a screw feeder.

The fluidized bed reactors have the upward moving stream of 600C gas composed of CO, CO<sub>2</sub>, H<sub>2</sub>, CH<sub>4</sub> and H<sub>2</sub>O. The hydrogen reacts with the iron ore, combining with its oxygen to form water (the only process by-product). Carbon from the carbonaceous gases combines with the elemental iron to form iron carbide. The methane provides the gas system equilibrium.

After the reactions in the fluid bed reactors, the off gases are condensed to get rid of water vapor, reconstituted with H<sub>2</sub> and carbonaceous gases, raised to reactor working pressure to 1.8 atm, heated to 600C, and reintroduced in the windbox of the reactor.

An indication of the inherent thermal efficiency of the process is gained from the fact that the temperature of formation of iron carbide in the fluid bed reactor is only 600C as against around 1000C for reduction of iron in DRI processes and 1500C to produce hot metal in the blast furnace.

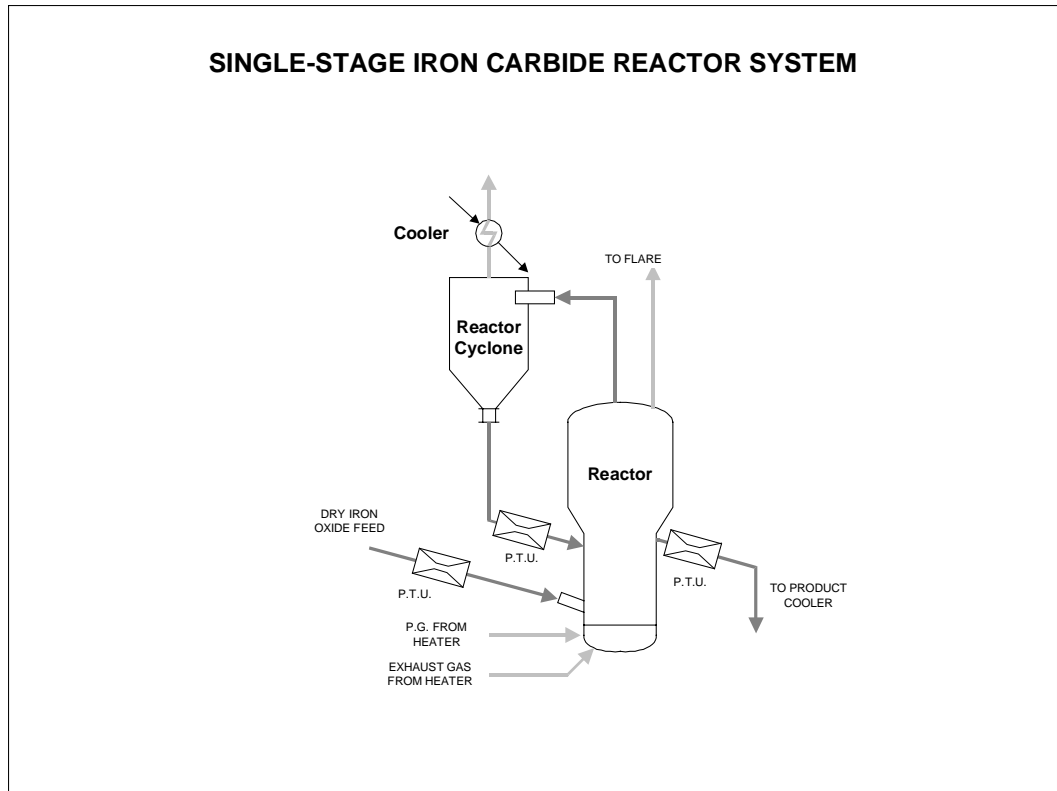
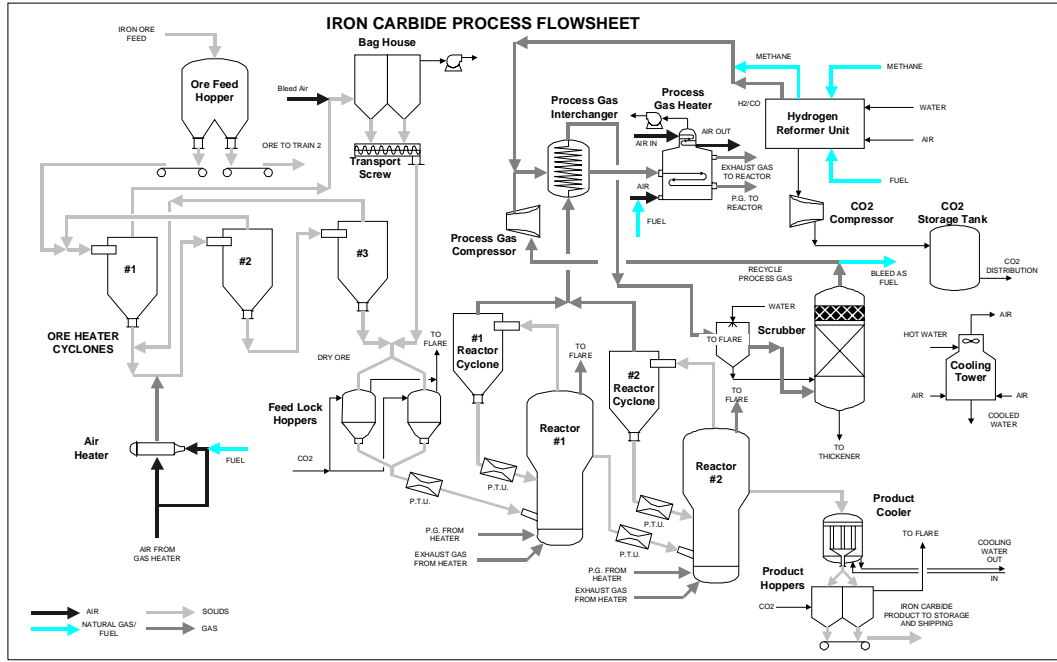
#### PROCESS ADVANTAGES

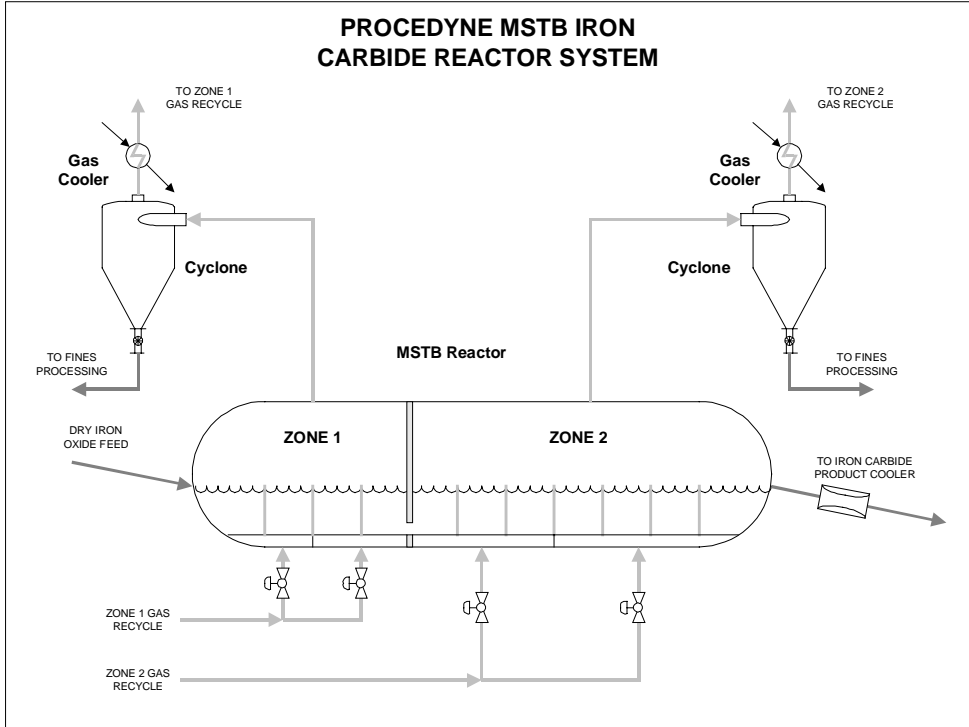
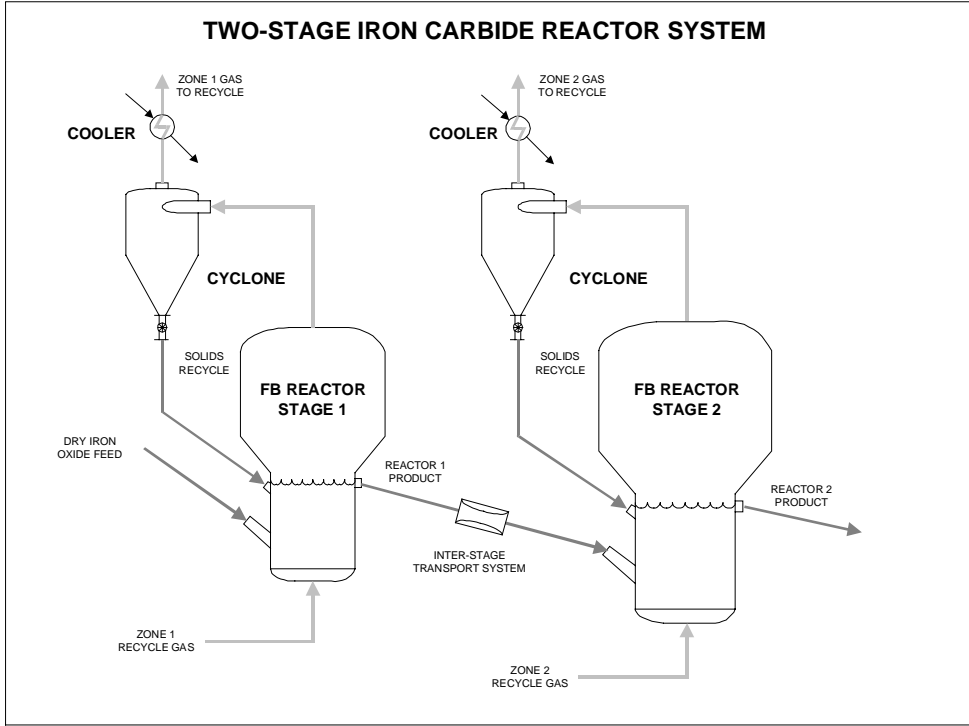
Lower operating temperature

Lower production costs

No storage costs as the product does not oxidize

Steelmaking cheaper with Fe<sub>3</sub>C







---

### 3-2.5 OTHER (REACTOR, ETC.)

#### Hismelt

##### PROCESS BACKGROUND:

The Hismelt process was initially developed as an air-blown, bottom-injected, refractory-lined process. But due to excessive refractory wear, the initial horizontal design was abandoned and a new Vertical smelt reduction vessel (SRV) was proposed.

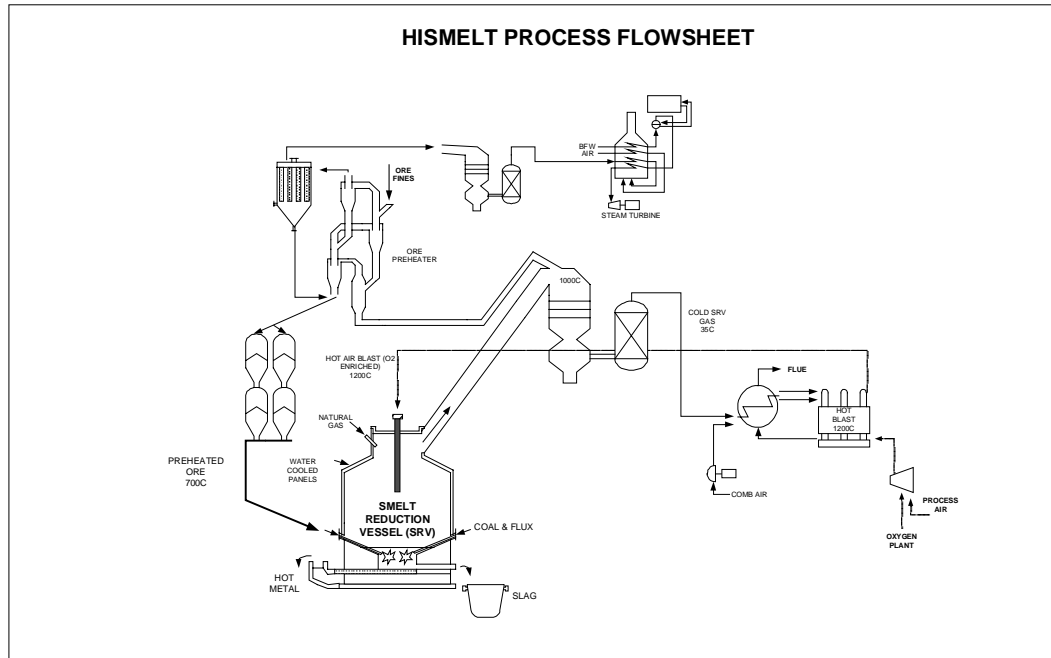
##### PROCESS DESCRIPTION:

In this process, the iron ore is preheated (and optionally prereduced as far as magnetite) in a lean-phase cyclone preheat system similar to that on many cement kilns. It is then injected into the SRV, along with coal and flux materials through two water-cooled solids injection lances such that the mixture is carried predominantly into the metal phase. Rapid dissolution and smelting occur in the metal and the resulting product gases (mainly hydrogen and carbon monoxide) rise under buoyancy to generate the large liquid fountain, a characteristic of Hismelt. The result is strong mixing within the metal and slag phases with effective elimination of any significant thermal gradients.

Hot offgas from the SRV is enriched with a small quantity of natural gas, the resulting mixture being roughly equivalent to blast furnace gas. This gas is cooled to around 1000C and split into roughly equal proportions. One portion is used (hot) in the preheater, whilst the other is scrubbed and subsequently burned as fuel in the hot blast stoves.

##### PROCESS ADVANTAGES

Direct smelting  
Low direct electrical power consumption



## Dios

### PROCESS BACKGROUND:

The Dios process is a bath smelting process, intensively investigated in Japan. For testing program, 100t smelters are constructed from remodeled BOF converters. Successful operational procedures have been established and an output rate of 40t/hr of hot metal is reported.

### PROCESS DESCRIPTION:

Iron ore is preheated in the first of two fluidized bed reactors in series and pre-reduced to 15-25% in the second reactor using cleaned offgas from the smelter. It is claimed that the high thermal efficiency through pre-reduction operation has the potential for using less expensive coal and lower consumption compared with BF route. In addition, a small amount of coal fines is injected into the smelter offgas to cool the offgas and provide additional CO and H<sub>2</sub> for pre-reduction. Coal is gravity fed into the smelter.

---

Oxygen is injected into the smelter for combustion of primary coal and for post combustion.

#### PROCESS ADVANTAGES

Direct smelting process  
Use of coal as reductant  
Low direct electrical power consumption

#### **Romelt Process**

##### PROCESS BACKGROUND:

The Romelt process is a bath smelting technology for converting iron oxides (either virgin iron ores or iron bearing waste materials) to blast furnace – grade pig iron using non-coking grades of coal as a fuel and reductant. Liquid, granulated, or cast pig iron have the highest “value-in-use” of all scrap substitutes, as they contain no gangue, have low residuals, and a high carbon content, and hence enable the EAF to produce high quality steel grades while simultaneously increasing furnace productivity.

##### PROCESS DESCRIPTION:

The iron oxide feed to a Romelt furnace can be any iron containing material, e.g. iron ore fines and concentrates, blast furnace and BOF dusts and sludges, mill scale, iron bearing slags from non-ferrous smelting operations, scarfs and turnings, iron dusts, etc. The non-coking coals of 15-20% volatile matter and approx. 8% ash have been used in past. The solid feeds (coal, iron oxides, and fluxes) are charged by gravity in the furnace.

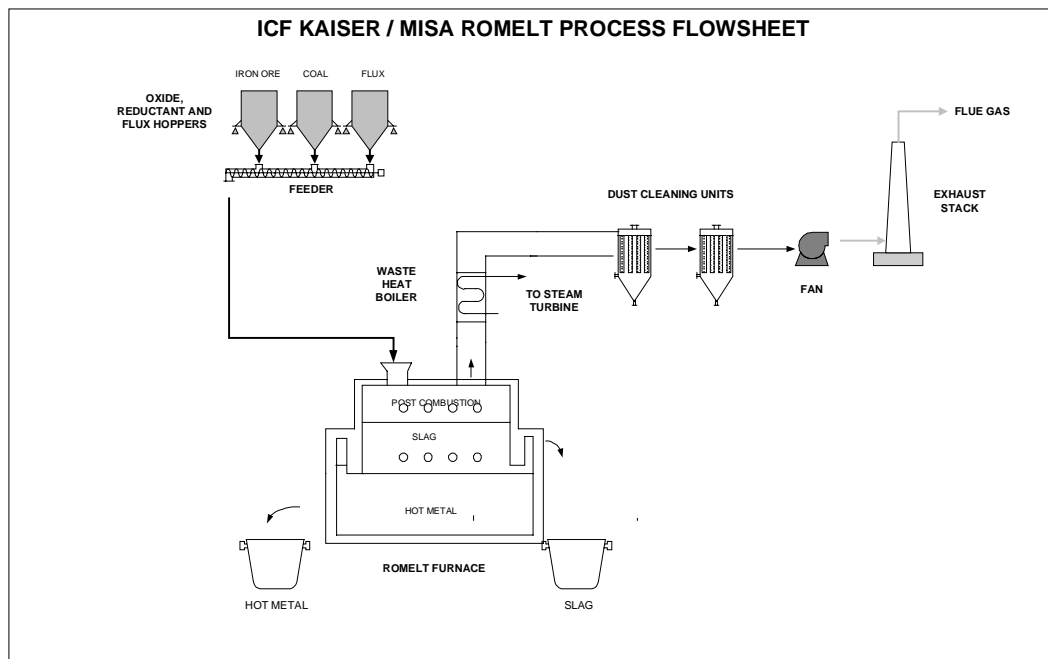
A row of lower blast tuyeres on each side of the furnace introduce oxygen to agitate the bath and gasify some coal, while upper tuyeres blow oxygen for post-combustion. The furnace operates under a slight pressure, with an induced draft fan drawing the waste gases out of the furnace and through the off-gas system. Hot metal and slag are removed periodically through separate tapholes in either end of the furnace. The hearth and lower walls of the furnace are refractory lined, and the upper walls of the furnace are made up of a series of water-cooled panels. The furnace consists of four zones:

Quiescent metal zone, Quiescent slag zone, Agitated slag zone and Gas combustion zone.

The bulk of the reduction process takes place in the agitated slag zone. Interaction between the metal and slag in both the agitated and quiescent zones allows partitioning of minor elements between these two phases to take place. Gases generated in the bath (predominantly CO and H<sub>2</sub>, with some N<sub>2</sub>) enter the combustion zone where they react with the oxygen from the upper blast, liberating energy.

### PROCESS ADVANTAGES

- Wide variety of raw material
- Solid waste disposal
- Low direct electrical power consumption



---

## Gridsmelter

### PROCESS BACKGROUND:

The Gridsmelter process is based upon a melter-gasifier that melts efficiently pre-reduced fine ore (60% to 80%) with some coke and coal in a grid smelter reactor vessel. Reduction is carried out at typical reduction temperatures. The process produces liquid pig iron as a product.

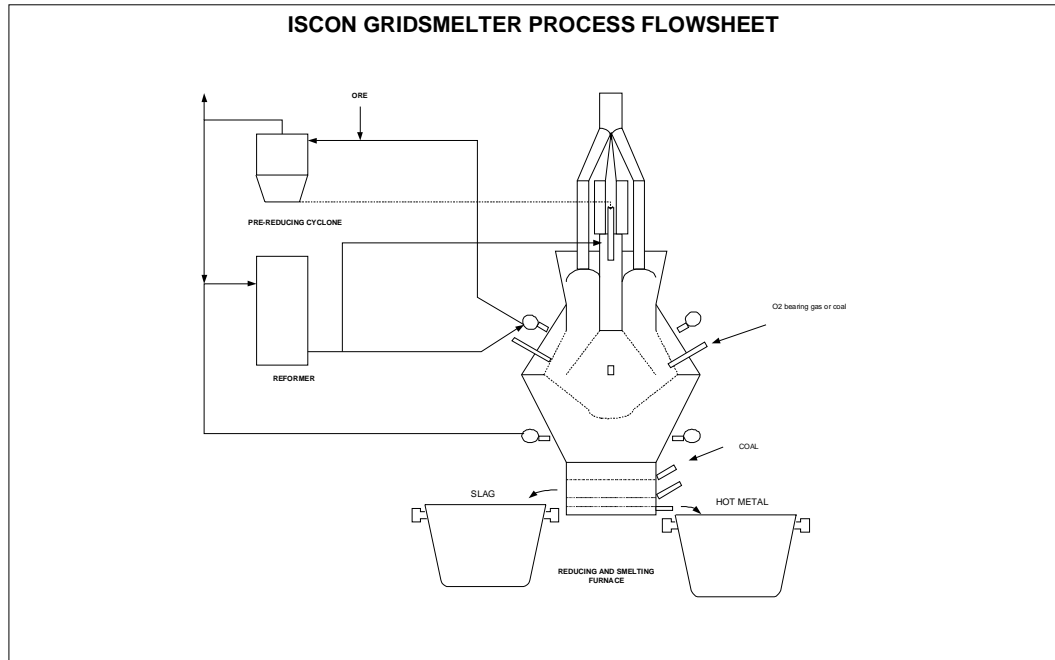
### PROCESS DESCRIPTION:

The Gridsmelter process consists of a melter-gasifier for using iron-containing fines as the primary feedstock. It is a pressure vessel with internal refractory lining of walls. The high temperature wall area and roof, where fine coal, natural gas or oil burns with preheated air or oxygen are water-cooled. The grid that supports a coke/refractory filter bed is also water-cooled.

The region above the grid (high temperature zone) is very similar to the raceway of a Blast furnace. In this high temperature zone, the final reduction and liquification take place. The liquified materials pass through the filter bed in co-current with the gases. FeO droplets formed are reduced, carburized and separated from the leaving gases, falling down into the furnace hearth. The furnace hearth contains liquid pig iron, slag and a bubbling fluidized coal/coke bed. The offgas leaves the vessel in the middle of the vessel height. The gas is hot cleaned by cyclone and used for pre-reduction and preheating of the feedstock and blast preheating.

### PROCESS ADVANTAGES

Wide variety of raw materials like sponge iron, iron ore fines, mill scale, etc.  
Takes advantage of 'sticking effect'  
Low direct electrical power consumption  
Liquid hot metal product



## Comet Process

### PROCESS BACKGROUND:

The Comet process, developed by the Centre de Recherches Metallurgiques (CRM), Belgium is a coal-based system that produces sponge iron from ore fines and limestone in a rotary hearth furnace. A laboratory, 100-kg/hr installation was brought on-stream in Nov. 1996. (Cockerill Sambre, Profil Arbed, Sidmar and Hoogovens have acquired the CRM license for the process.)

Based on the successful results obtained, a pilot 1.5-tonne/hour plant has been built at Sidmar, Ghent, Belgium. Metallization results confirm those obtained from the laboratory unit. Productivity, cost, price, energy consumption and environmental impact are being established.

---

PROCESS DESCRIPTION:

Similar to Fastmet or Inmetco.

PROCESS ADVANTAGES

Direct use of low cost iron ore fines  
Low cost reductant  
Less reduction time  
Proven equipment usage

**FINEX Process**

PROCESS BACKGROUND:

The FINEX process produces liquid iron (hot metal) using fine iron ore and non-coking coal directly without any pre-treatment process for raw materials and fuel such as sintering process for raw materials and coking process for coal in the blast furnace ironmaking process.

PROCESS DESCRIPTION:

FINEX Development Project in POSCO in Sanghoon Joo RIST, Republic of Korea

The detailed objectives are as follows:

Finex, a coal-based smelting reduction process, continues to be jointly developed by Posco, RIST and Voest-Alpine. This process is reported to be a more advanced smelting reduction technology than Corex. A 150-tonne/day pilot plant is under construction at the Posco Pohang Works based on the success achieved with a smaller 15-tonne/day unit: completion is scheduled for March 1999. It is reported that advantages include the use of fine ore and non-coking coal together with lower construction costs, reduced emissions and lower manpower and production costs than the Corex process.

---

## PROCESS ADVANTAGES:

Direct use of ore fines (-8 mm) without sintering  
Direct use of non-coking coal without the coke oven for ironmaking  
Reduced hot metal production cost  
An environment-friendly ironmaking process  
Operational flexibility in ironmaking process.  
Contact : Ernst Worrell

## Plasma Processes

### PROCESS BACKGROUND:

In plasma smelting for direct reduction, gases and solids are passed through an arc, much like a welding arc, and are heated. This electric heating replaces oxygen in conventional systems that use oxy-fuel burners.

The **Plasmasmelt** process produces molten iron from pre-reduced iron ore. A plasma torch consisting of a pair of tubular, water-cooled copper electrodes discharges an electric arc which is magnetically rotated at very high speeds. The electrodes are spaced closely together and during operation, a process gas is injected through the narrow gap between the electrodes. The arc current can be varied independent of gas flow rate and thus, process temperatures can be controlled.

### PROCESS DESCRIPTION:

In this process, the shaft is completely filled with coke. The reactions take place in the shaft furnace with tuyeres spaced symmetrically around the lower part of the furnace. Plasma generators and equipment for injection of metal oxides mixed with slag-forming material and possibly reductants are attached to the tuyeres. In front of each tuyere a cavity is formed inside the coke column where reduction and smelting take place. At regular intervals the produced slag and metal are tapped from the bottom of the shaft furnace. During iron ore smelting, the off-gas from the furnace, consisting mainly of carbon monoxide and hydrogen, are used for pre-reduction of the ore.



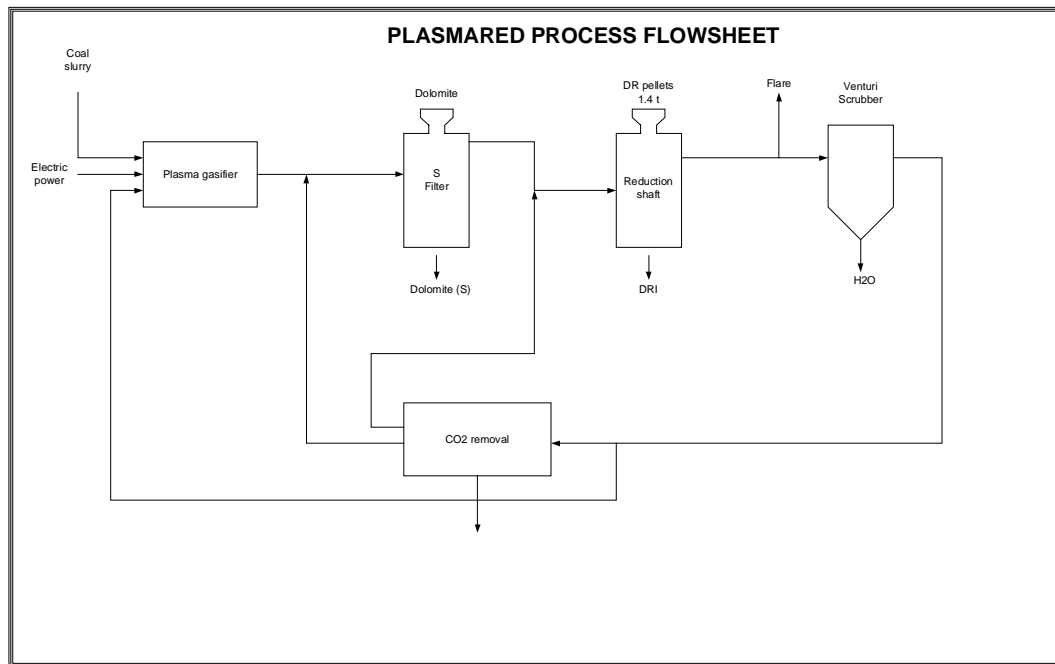
In case the ore contains metals with high vapor pressures, for example zinc and lead, these metals leave the furnace with the off-gas that is then passed through a condenser where the metals are recovered from the gas.

#### PROCESS ADVANTAGES:

A negative advantage is that it takes an enormous amount of electrical power to produce the desired results.

### PlasmaRed

This process utilizes the plasma energy specifically to generate a reducing gas for DRI Production in a shaft furnace, not for metal melting or ore smelting. It has the potential for higher efficiencies of electrical power usage.



---

## AISI Process

### PROCESS BACKGROUND:

The AISI direct steelmaking project was a collaborative research programme heavily supported by the US DOE, by the Steel industry and by academic institutions. But now it has been discontinued largely. Hoogovens has continued some work in this area as a source of semi-reduced feedstock for their other project, the cyclone converter furnace.

### PROCESS DESCRIPTION:

The AISI process directly uses fine ores and coals to produce molten iron in a two-stage process. In the first stage, ore is pre-reduced and melted in a melting cyclone. Directly connected to the melting cyclone is a converter type vessel where pre-reduced and melted ore undergoes final reduction. Post-combustion of gases takes place that improves energy efficiency, and the waste gases are used for pre-reduction of the pellets. A vertical smelter was used initially, but a design change to a horizontal reactor has been made which is expected to improve productivity and flexibility.

### PROCESS ADVANTAGES

Direct smelting process  
Produces liquid hot metal  
Reduced direct electrical power consumption

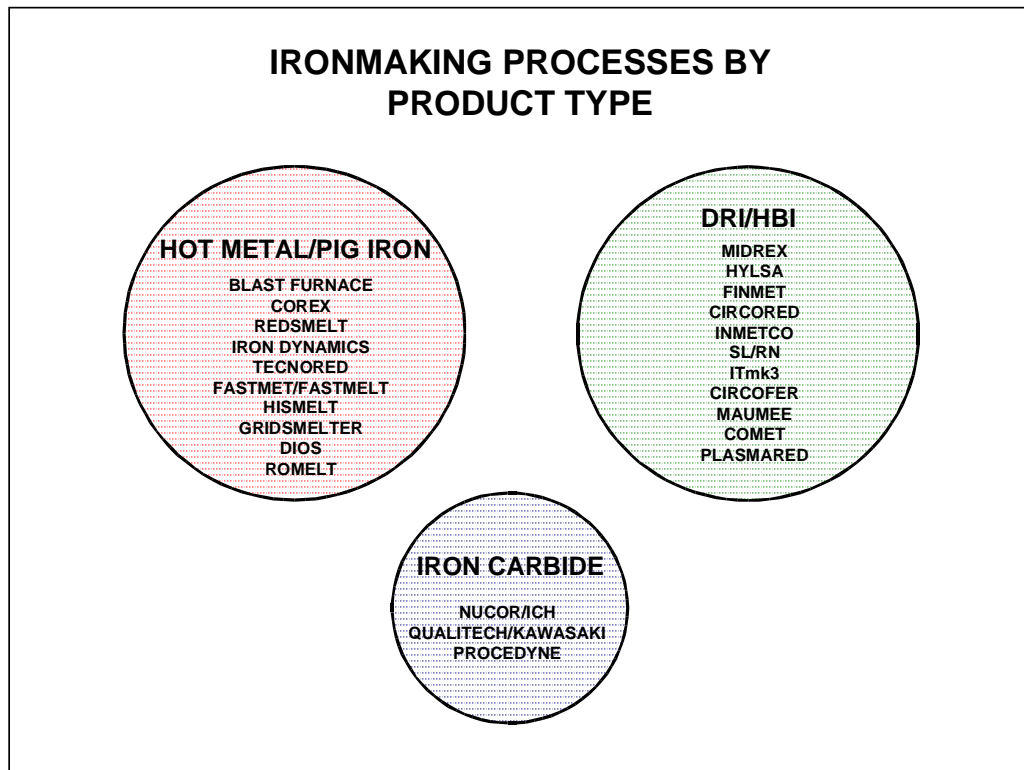
## **3-3: Process Groupings**

In the initial screening analysis of the various Ironmaking processes, there was an attempt to categorize or group the processes into similar groups. The purpose was to be in a position to select one or two outstanding Ironmaking processes from a given group to compare with selected processes from other groups. These efforts were not completely successful due to the diverse nature of the various Ironmaking processes, the variety of forms of iron produced and the different sources of energy utilized for the processes.

Although not specifically utilized in this study, the exercise of grouping processes had some meaning. A short summary of these groupings is presented below. A more comprehensive presentation is in Volume II, Appendix A-4.

### 3-3.1 Grouping By Product Type

One grouping of Ironmaking processes is by Product Type. That is by what type of iron unit is being produced by the product. The groupings for product type selected were: Hot Metal/Pig Iron, DRI/HBI and Iron Carbide.

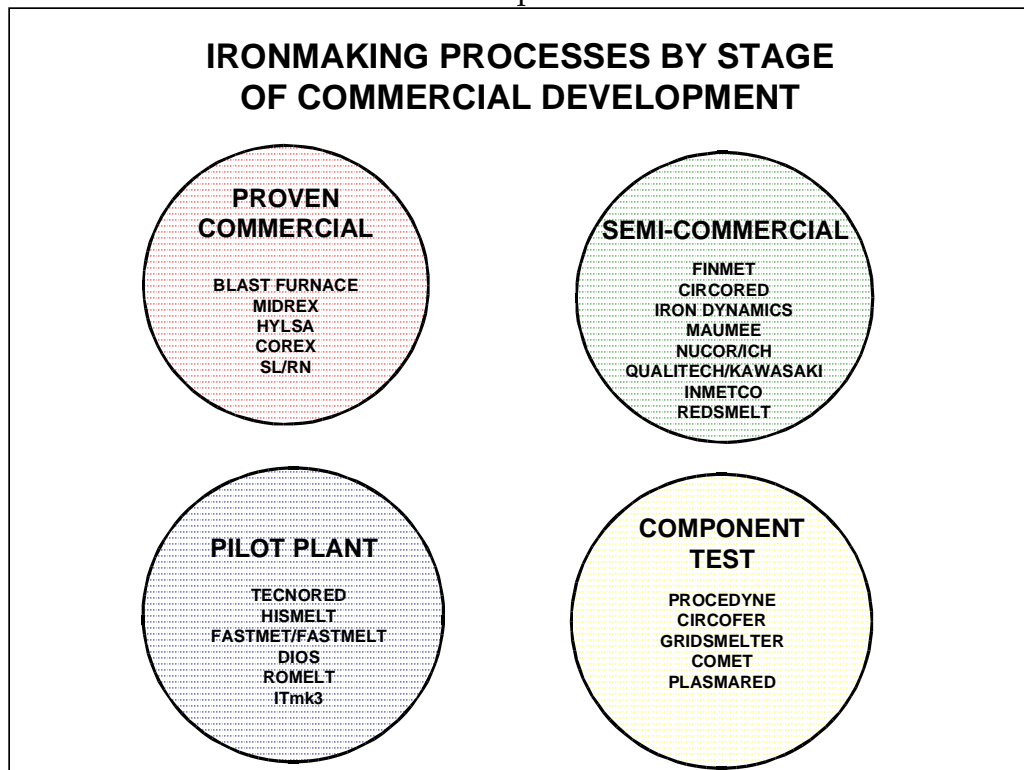


Rev. 06-June-00

### 3-3.2 Grouping by Stage of Commercial Development

Another grouping of Ironmaking processes is by Stage of Commercial Development. The groupings utilized are:

- Proven Commercial The process is operating commercially in more than one economically-viable installation.
- Semi-Commercial The process is undergoing startup in a first-of-a-kind commercial scale installation or is still in process demonstration phase. This also includes those that are no longer being operated.
- Pilot Scale The process has been operated at an integrated pilot scale.
- Semi-Pilot Component Test Parts of the process have been operated at a pilot scale.

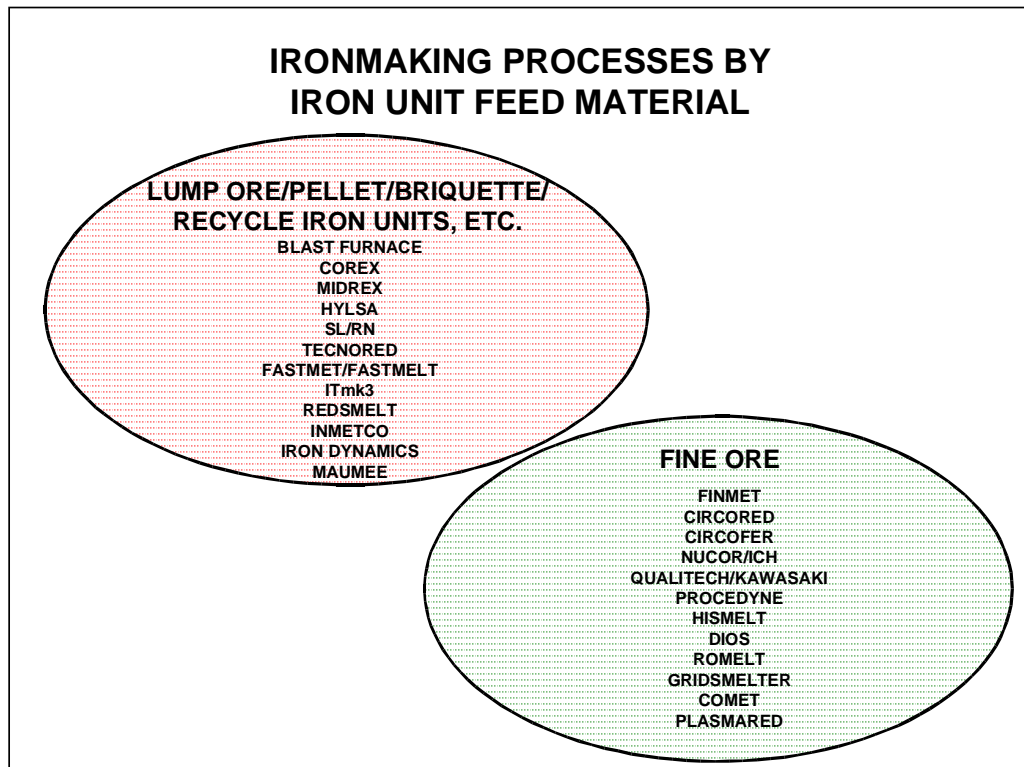


Rev. 06-June-00

### 3-3.3 Grouping by Iron Unit Feed Material

An important grouping of Ironmaking processes is by the nature of the process Iron Unit Feed Material. Categories for grouping chosen include:

- Lump Ore/Iron Ore Pellets/Briquetted Feed/ Recycled Iron Units, etc.: The intent of this grouping (which could be sub-grouped further) was to compare those processes that predominately utilized natural lump iron ore or a prepared (e.g. palletized, briquetted, etc.) iron unit feed.
- Fine Ore: The intent of this grouping was to emphasize that processes that utilize fine ore (or concentrates) directly without agglomeration or complex preparation may have distinct economic advantages.

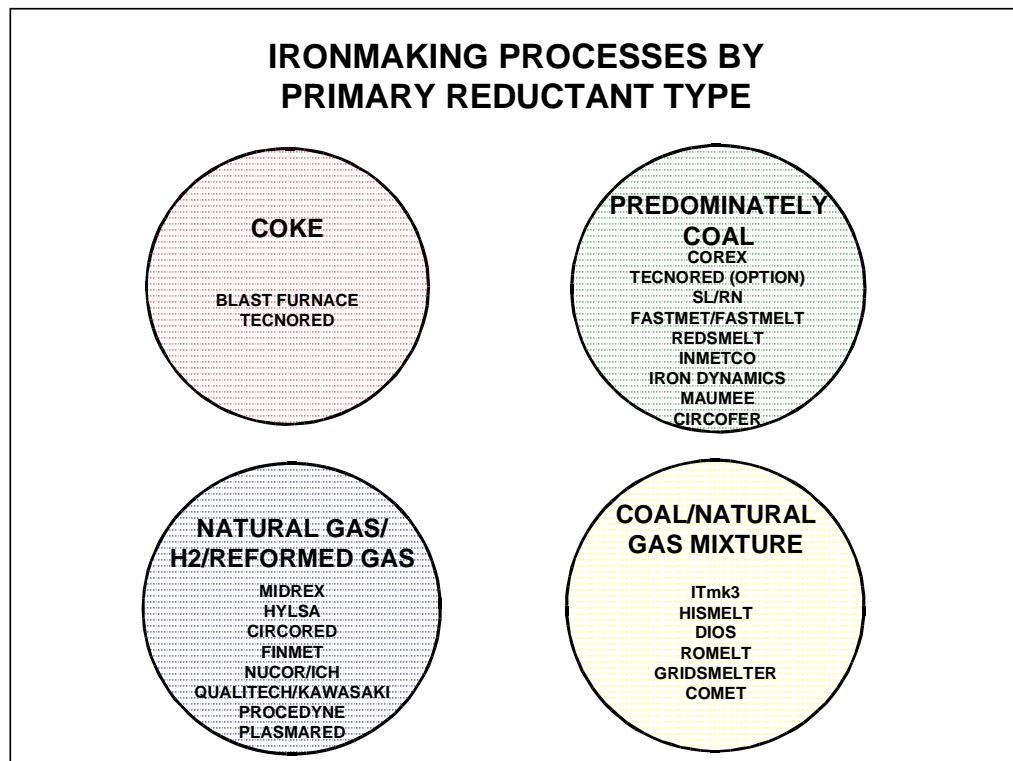


Rev. 06-June-00

### 3-3.4 Grouping by Primary Reductant Type

An important categorization criteria for Ironmaking processes is to group by Primary Reductant Type. The groupings are as follows:

- **Coke:** Metallurgical grade coke or coke of lesser quality (e.g. for Tecnoled) is the primary reductant source.
- **Predominately Coal:** Non-Metallurgical coal is the primary reductant and fuel.
- **Natural Gas/Reformed Gas:** Either natural gas (subsequently reformed or used directly) and Reformed Gas (e.g. Sasol gas, Corex off-gas, etc.) is the primary reductant and fuel.
- **Mixed Coal/Natural Gas systems** utilize a balanced mixture of coal and natural gas as the fuel and/or reductant source.

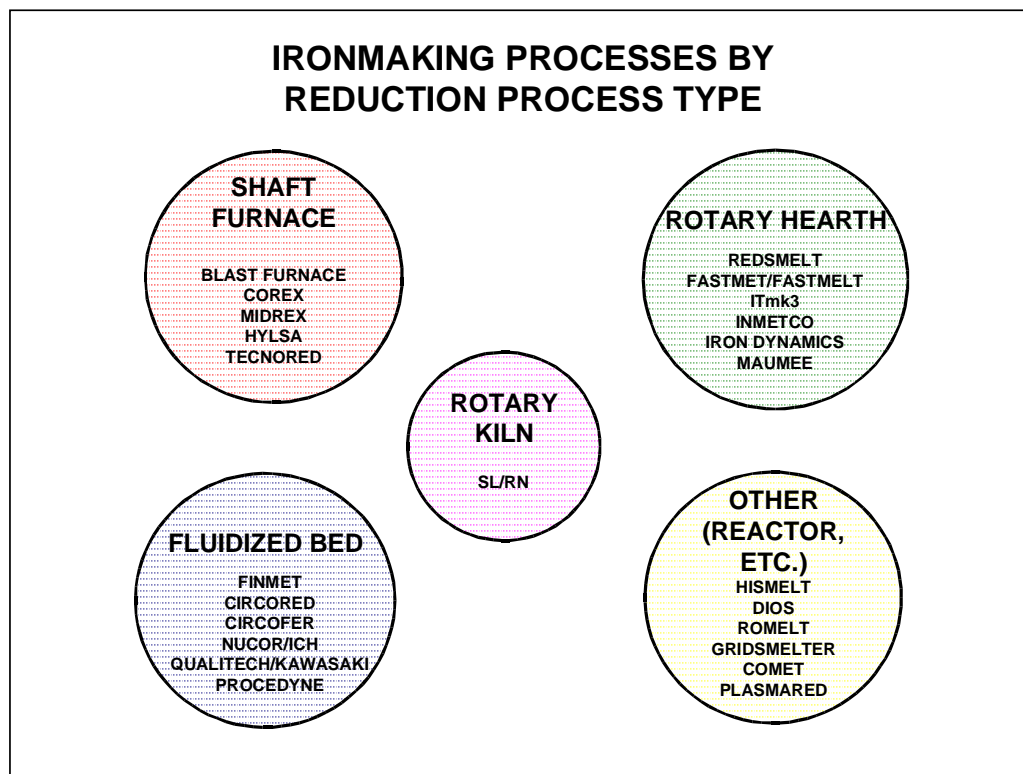


Rev. 06-June-00

### 3-3.5 Grouping by Reduction Process Type

A meaningful method of categorizing Ironmaking processes is to group by Reduction Process Type. The groupings utilized include:

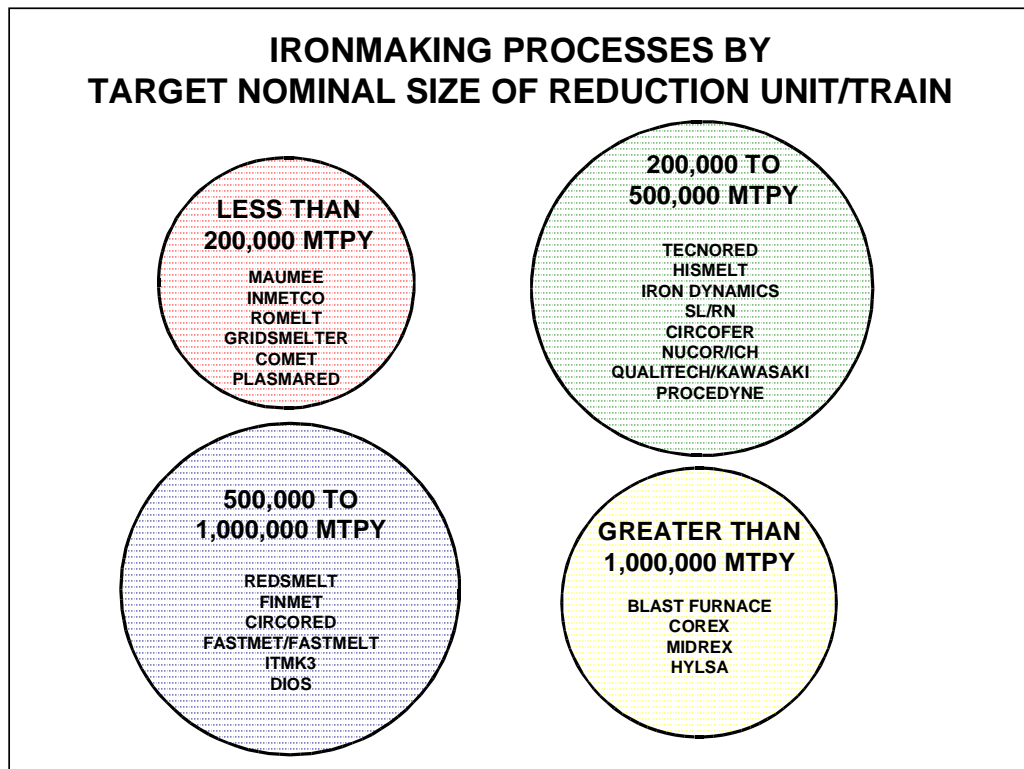
- Shaft Furnace: Includes hot metal and DRI producing shaft furnaces. Flow of solids and liquids are counter-current to the reducing or heating gases. Part of the reductant may be added in solid form.
- Rotary Kiln: This is processes where the primary reduction is done in a rotary kiln. Solid or gaseous reductants (or a mixture) are possible.
- Rotary Hearth: A number of processes utilize a rotary hearth as the primary furnace where reduction occurs. Solid or gaseous reductants (or a mixture is possible).
- Fluidized Bed: There are fine ore-based processes where the ore is fluidized and transported by the reducing gas.
- Other (Reactor, etc.): The remaining Ironmaking processes where a reactor is utilized for the primary reducing vessel.



Rev. 06-June-00

### 3-3.5 Grouping by Target Nominal Size of Reduction Unit/Train

This attempt at categorizing is based on the Nominal Size of the Primary Reduction Unit or Single-Train.



Rev. 06-June-00

It should be noted that the categorization as done in Section 3-3.5, i.e. Grouping by Reduction Process Type is the method selected for the comparative process evaluation.



---

## Section 4: Discussion of Ranking Analysis

### 4-1: Ranking Variables Considered

The methodology followed in comparing the various Ironmaking Processes was to sort and rank the processes by the order of the specific process variables considered. That is, the process with the lowest (or highest) value as appropriate for a specific variable is ranked first, the next lowest (or highest), is ranked second, and so on until the poorest process is ranked last.

The selected processes are listed in Section 3-1.2.

The ranking variables include:

- **Capital Cost (CAPEX):** The Relative Capital Costs as \$/Annual metric ton of Liquid Refined Steel Production of the Ironmaking/EAF/LRF Steelmaking processes as summarized in Section 2-4.1 and in detail in Volume II, Appendix F-5.
- **Operating Costs Per Iron Unit (OPEX I.U.):** The Relative Operating Costs of the Iron Unit Production as summarized in Section 2-4.3 and in detail in Volume II, Appendix F-4.
- **Operating Costs Per LRS Production:** The Relative Operating Costs per mt of LRS as summarized in Section 2-4.3 and in detail in Volume II, Appendix F-4.
- **Simple Internal Rate Of Return (I.R.R.):** Utilizing the Relative Capital and Operating Costs for LRS, a simple rate of return calculation was done to combine the impacts of Capital and Operating Costs. These are summarized in Volume II, Appendix G-1.
- **Total Cumulative Electric Power Consumption:** The cumulative electric power consumption (Volume II, Appendix F-3) through production of LRS.
- **Total Cumulative Process Emissions:** The Cumulative emissions of carbon gases (as CO<sub>2</sub>) from the Processes only (Volume II, Appendix F-3).

- 
- **Total Cumulative Emissions:** The cumulative emissions of carbon gases (as CO<sub>2</sub>) from the Process and the equivalent emissions from the total cumulative electrical power through production of LRS (Volume II, Appendix F-3).

The following tables summarize the specific variable quantities compared in the sorting and ranking exercises. These are sensitized by the cost of purchased steel scrap used in the EAF/LRF steelmaking processes. The derivation and explanation of these tables for the selected processes are presented in Volume II, Appendix G-1.

**Table 4-1.1: Basis: \$100/mt of Steel Scrap**

**VARIABLES FOR RANKING OF IRONMAKING PROCESSES - RESEQUENCED**

SEQ. NO.	PROCESS	CAPEX (\$/ANN. mt L.S.)	OPEX FOR I.U. (\$/ANN. mt I.U.)	OPEX FOR L.S. (\$/ANN. mt L.S.)	INTERNAL RATE OF RETURN	TOTAL ELEC. (kWhr/mt LS)	PROCESS CO2 (mt/mt LS)	TOTAL CO2 (mt/mt LS)
1	100% DRI, 1.0% C, MIDREX	\$365.36	\$132.44	\$205.39	10.57%	1,326.73	1.0514	2.2617
2	100% STEEL SCRAP	\$173.68	\$0.00	\$176.83	42.09%	822.45	0.0874	0.8909
3	30% DRI, 1.0% C/70% SCRAP	\$231.85	\$137.51	\$188.64	26.21%	1,030.37	0.4283	1.3681
4	HYLSA IVM	\$362.60	\$125.52	\$196.15	13.72%	1,267.37	0.9086	2.0646
5	30% BF H.M./70% SCRAP CP COKE	\$243.64	\$142.86	\$189.65	24.46%	795.44	0.8974	1.6746
6	30% MINI-BF H.M.*	\$198.05	\$142.86	\$189.65	30.32%	795.44	0.8974	1.6746
7	30% BF H.M./70% SCRAP NR COKE	\$243.63	\$110.77	\$178.23	29.28%	660.35	0.9594	1.5615
8	30% COLD PIG IRON/70% SCRAP	\$248.06	\$145.12	\$198.05	20.43%	1002.39	0.9027	1.8170
9	30% TECNORED H.M. W COGEN	\$196.48	\$125.95	\$177.67	36.74%	307.58	1.1545	1.4350
10	30% TECNORED H.M. W/O COGEN	\$187.71	\$163.09	\$190.98	31.30%	685.69	1.1545	1.7799
11	COREX/MIDREX WITH 60% H.M.	\$373.50	\$161.83	\$218.17	5.72%	942.91	2.9239	3.7839
12	HISMELT 32.7% H.M.	\$259.63	\$137.85	\$190.82	22.39%	847.37	0.8689	1.6418
13	REDSMELT	\$334.67	\$101.83	\$188.31	17.73%	690.28	1.3624	1.9921
14	MAUMEE BRIQUETTE DR/EAF	\$292.32	\$66.44	\$177.03	24.66%	966.09	1.1498	2.0310
15	ITMK3 DR SHOT TO EAF	\$296.10	\$67.60	\$178.76	23.72%	825.40	1.5213	2.2742
16	CIRCORED/HBI/EAF	\$232.37	\$78.79	\$185.27	27.64%	900.84	1.1999	2.0217
17	CIRCOFER/HBI/SAF/EAF	\$239.63	\$96.20	\$188.55	25.37%	780.99	1.6404	2.3528
18	FINMET/HBI/EAF	\$263.47	\$79.42	\$185.12	24.31%	907.76	1.0742	1.9022
19	GENERIC IRON CARBIDE (100%)/EAF	\$347.59	\$66.19	\$177.84	20.24%	972.95	1.2864	2.1738
20	GENERIC I.C. (40%)/SAF/EAF*	\$257.24	\$100.79	\$179.90	27.02%	1185.22	1.3320	2.0648
21	SL/RN ROTARY KILN	\$344.39	\$74.08	\$180.74	19.55%	999.74	2.2869	3.1988

Table 4-1.2: Basis: \$120/mt of Steel Scrap

VARIABLES FOR RANKING OF IRONMAKING PROCESSES - RESEQUENCED								
SEQ. NO.	PROCESS	CAPEX (\$/ANN. mt L.S.)	OPEX FOR I.U. (\$/ANN. mt I.U.)	OPEX FOR L.S. (\$/ANN. mt L.S.)	INTERNAL RATE OF RETURN	TOTAL ELEC. (kWhr/mt LS)	PROCESS CO2 (mt/mt LS)	TOTAL CO2 (mt/mt LS)
1	100% DRI, 1.0% C, MIDREX	\$365.36	\$132.44	\$205.39	10.57%	1,326.73	1.0514	2.2617
2	100% STEEL SCRAP	\$173.68	\$0.00	\$197.39	30.14%	822.45	0.0874	0.8909
3	30% DRI, 1.0% C/70% SCRAP	\$231.85	\$137.51	\$203.36	19.55%	1,030.37	0.4283	1.3681
4	HYLSA IVM	\$362.60	\$125.52	\$196.15	13.72%	1,267.37	0.9086	2.0646
5	30% BF H.M./70% SCRAP CP COKE	\$243.64	\$142.86	\$204.39	18.04%	795.44	0.8974	1.6746
6	30% MINI-BF H.M.*	\$198.05	\$142.86	\$204.39	22.64%	795.44	0.8974	1.6746
7	30% BF H.M./70% SCRAP NR COKE	\$243.63	\$110.77	\$192.97	23.04%	660.35	0.9594	1.5615
8	30% COLD PIG IRON/70% SCRAP	\$248.06	\$145.12	\$212.79	13.89%	1002.39	0.9027	1.8170
9	30% TECNORED H.M. W COGEN	\$196.48	\$125.95	\$192.41	29.14%	307.58	1.1545	1.4350
10	30% TECNORED H.M. W/O COGEN	\$187.71	\$163.09	\$205.72	20.25%	685.69	1.1545	1.7799
11	COREX/MIDREX WITH 60% H.M.	\$373.50	\$161.83	\$218.16	5.72%	942.91	2.9239	3.7839
12	HISMELT 32.7% H.M.	\$259.63	\$137.85	\$198.19	19.38%	847.37	0.8689	1.6418
13	REDSMELT	\$334.67	\$101.83	\$190.67	16.96%	690.28	1.3624	1.9921
14	MAUMEE BRIQUETTE DRI/EAF	\$292.32	\$66.44	\$177.03	24.66%	966.09	1.1498	2.0310
15	ITMK3 DR SHOT TO EAF	\$296.10	\$67.60	\$181.12	22.89%	825.40	1.5213	2.2742
16	CIRCORED/HBI/EAF	\$232.37	\$78.79	\$185.27	27.64%	900.84	1.1999	2.0217
17	CIRCOFER/HBI/SAF/EAF	\$239.63	\$96.20	\$188.55	25.37%	780.99	1.6404	2.3528
18	FINMET/HBI/EAF	\$263.47	\$79.42	\$185.12	24.31%	907.76	1.0742	1.9022
19	GENERIC IRON CARBIDE (100%)/EAF	\$347.59	\$66.19	\$177.84	20.24%	972.95	1.2864	2.1738
20	GENERIC I.C. (40%)/SAF/EAF*	\$257.24	\$100.79	\$192.65	21.87%	1185.22	1.3320	2.0648
21	SL/RN ROTARY KILN	\$344.39	\$74.08	\$183.10	18.81%	999.74	2.2869	3.1988

Table 4-1.3: Basis: \$140/mt of Steel Scrap

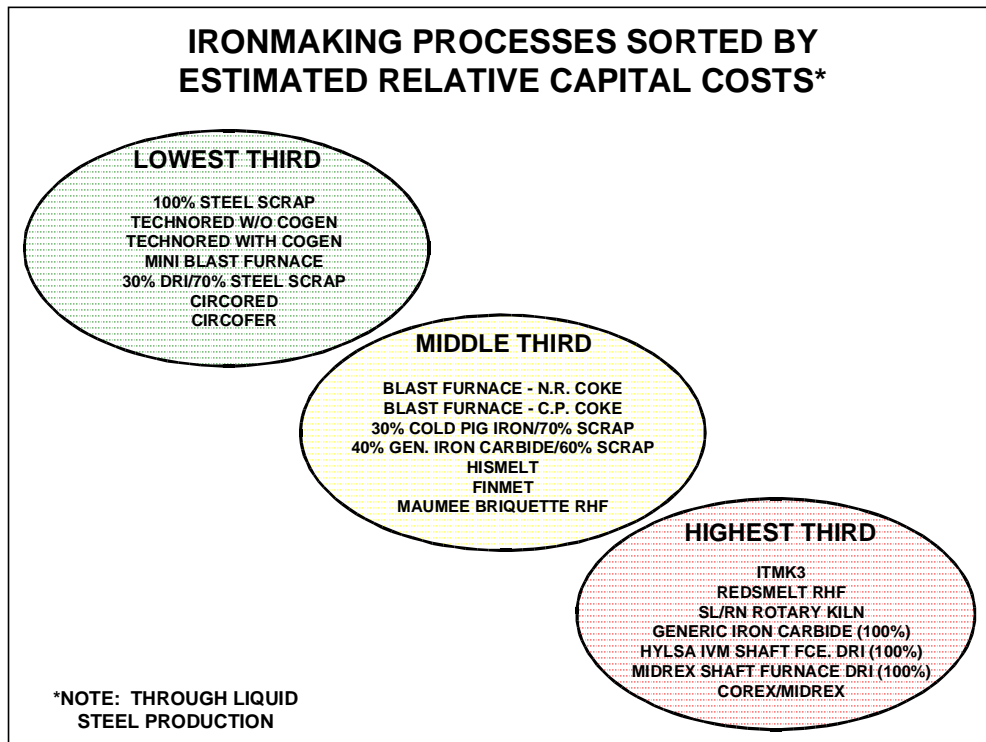
VARIABLES FOR RANKING OF IRONMAKING PROCESSES - RESEQUENCED

SEQ. NO.	PROCESS	CAPEX (\$/ANN. mt L.S.)	OPEX FOR I.U. (\$/ANN. mt I.U.)	OPEX FOR L.S. (\$/ANN. mt L.S.)	INTERNAL RATE OF RETURN	TOTAL ELEC. (kWhr/mt LS)	PROCESS CO2 (mt/mt LS)	TOTAL CO2 (mt/mt LS)
1	100% DRI, 1.0% C, MIDREX	\$365.36	\$132.44	\$205.39	10.57%	1,326.73	1.0514	2.2617
2	100% STEEL SCRAP	\$173.68	\$0.00	\$217.95	17.75%	822.45	0.0874	0.8909
3	30% DRI, 1.0% C/70% SCRAP	\$231.85	\$137.51	\$218.09	12.45%	1,030.37	0.4283	1.3681
4	HYLSA IVM	\$362.60	\$125.52	\$196.15	13.72%	1,267.37	0.9086	2.0646
5	30% BF H.M./70% SCRAP CP COKE	\$243.64	\$142.86	\$219.12	11.14%	795.44	0.8974	1.6746
6	30% MINI-BF H.M.*	\$198.05	\$142.86	\$219.12	14.56%	795.44	0.8974	1.6746
7	30% BF H.M./70% SCRAP NR COKE	\$243.63	\$110.77	\$207.70	16.55%	660.35	0.9594	1.5615
8	30% COLD PIG IRON/70% SCRAP	\$248.06	\$145.12	\$227.52	6.48%	1002.39	0.9027	1.8170
9	30% TECNORED H.M. W COGEN	\$196.48	\$125.95	\$207.14	21.36%	307.58	1.1545	1.4350
10	30% TECNORED H.M. W/O COGEN	\$187.71	\$163.09	\$220.45	14.74%	685.69	1.1545	1.7799
11	COREX/MIDREX WITH 60% H.M.	\$373.50	\$161.83	\$218.17	5.72%	942.91	2.9239	3.7839
12	HISMELT 32.7% H.M.	\$259.63	\$137.85	\$212.92	13.05%	847.37	0.8689	1.6418
13	REDSMELT	\$334.67	\$101.83	\$193.03	16.17%	690.28	1.3624	1.9921
14	MAUMEE BRIQUETTE DR/EAF	\$292.32	\$66.44	\$177.03	24.66%	966.09	1.1498	2.0310
15	ITMK3 DR SHOT TO EAF	\$296.10	\$67.60	\$183.48	22.05%	825.40	1.5213	2.2742
16	CIRCORED/HBI/EAF	\$232.37	\$78.79	\$185.27	27.64%	900.84	1.1999	2.0217
17	CIRCOFER/HBI/SAF/EAF	\$239.63	\$96.20	\$188.55	25.37%	780.99	1.6404	2.3528
18	FINMET/HBI/EAF	\$263.47	\$79.42	\$185.12	24.31%	907.76	1.0742	1.9022
19	GENERIC IRON CARBIDE (100%)/EAF	\$347.59	\$66.19	\$177.84	20.24%	972.95	1.2864	2.1738
20	GENERIC I.C. (40%)/SAF/EAF*	\$257.24	\$100.79	\$205.40	16.52%	1185.22	1.3320	2.0648
21	SL/RN ROTARY KILN	\$344.39	\$74.08	\$185.46	18.06%	999.74	2.2869	3.1988

## 4-2:            Sorting and Ranking By Capital Cost Estimates (Through L.S. Production)

The first variable sorted on was the Relative Capital Costs (as \$/Annual mt of RLS production based on 1.0 MM mt of RLS per year production). The processes were arranged by ascending Relative Capital Costs. These processes were also assigned a Rank based on their new sequence as a result of the Relative Capital Cost sorting. This rank variable is used later (in Section 4.9) as a basis for obtaining weighted Rankings of the processes bases on total variable combinations.

**Figure 4-2.1:**  
(Not sensitized by Purchased Scrap Cost)



Rev. 04-Aug-00

**Table 4-2.1: Sort by Capital Costs  
(Not sensitized by Purchased Scrap Cost)**

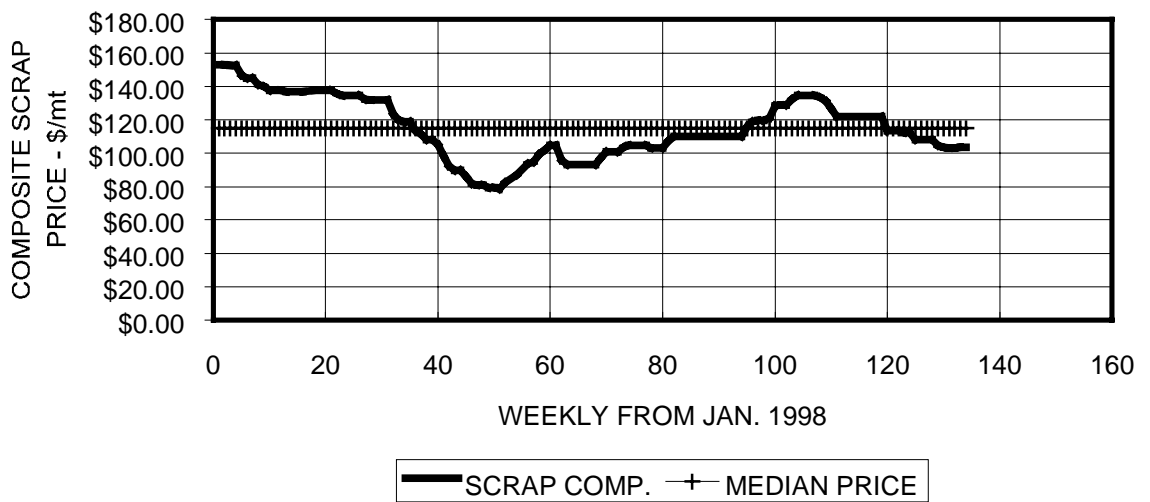
**VARIABLES FOR RANKING OF IRONMAKING PROCESSES - SORTED ON CAPEX**

<b>RANK (L.S.)</b>	<b>SEQ. NO.</b>	<b>PROCESS</b>	<b>CAPEX (\$/ANN. mt L.S.)</b>
<b>LOWEST THIRD</b>			
1	2	100% STEEL SCRAP	\$173.68
2	10	30% TECNORED H.M. W/O COGEN	\$187.71
3	9	30% TECNORED H.M. W COGEN	\$196.48
4	6	30% MINI-BF H.M.	\$198.05
5	3	30% DRI, 1.0% C/70% SCRAP	\$231.85
6	16	CIRCORED/HBI/EAFF	\$232.37
7	17	CIRCOFER/HBI/SAF/EAFF	\$239.63
<b>MIDDLE THIRD</b>			
8	7	30% BF H.M./70% SCRAP NR COKE	\$243.63
9	5	30% BF H.M./70% SCRAP CP COKE	\$243.64
10	8	30% COLD PIG IRON/70% SCRAP	\$248.06
11	20	GENERIC I.C. (40%)/SAF/EAFF	\$257.24
12	12	HISMELT 32.7% H.M.	\$259.63
13	18	FINMET/HBI/EAFF	\$263.47
14	14	MAUMEE BRIQUETTE DRI/EAFF	\$292.32
<b>HIGHEST THIRD</b>			
15	15	ITMK3 DR SHOT TO EAF	\$296.10
16	13	REDSMELT	\$334.67
17	21	SL/RN ROTARY KILN	\$344.39
18	19	GENERIC IRON CARBIDE (100%)/EAFF	\$347.59
19	4	HYLSA IVM	\$362.60
20	1	100% DRI, 1.0% C, MIDREX	\$365.36
21	11	COREX/MIDREX WITH 60% H.M.	\$373.50

### 4-3:            **Sorting and Ranking By Operating Costs Estimates Through Liquid Steel Production**

The Operating Costs for Liquid Steel Production are sensitized on Purchased Steel Scrap Cost. Sensitivity values used are: \$100/mt, \$120/mt and \$140/mt. These are based on Published Composite Steel Scrap Prices (AMM) as shown in Figure 2-3.1 reproduced below. It was determined that these sensitivity values presented a balance low, median and high Steel Scrap Costs for the last two years.

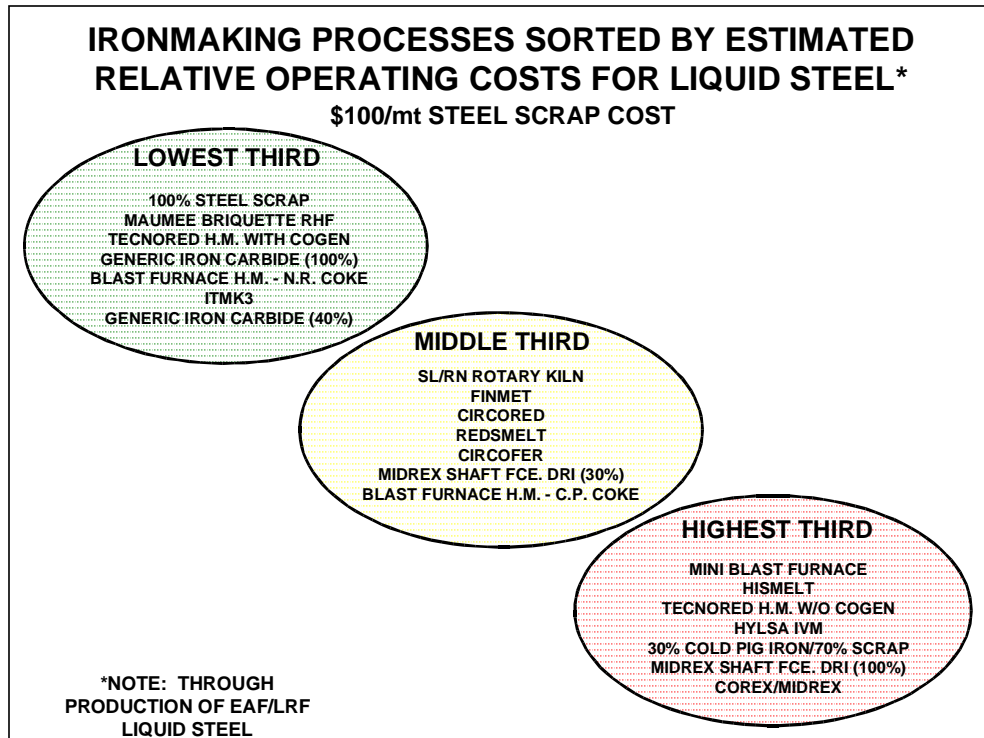
FIGURE 2-3.1: STEEL SCRAP PRICE COMPOSITE  
(\$/mt WEEKLY FROM JANUARY 1998)





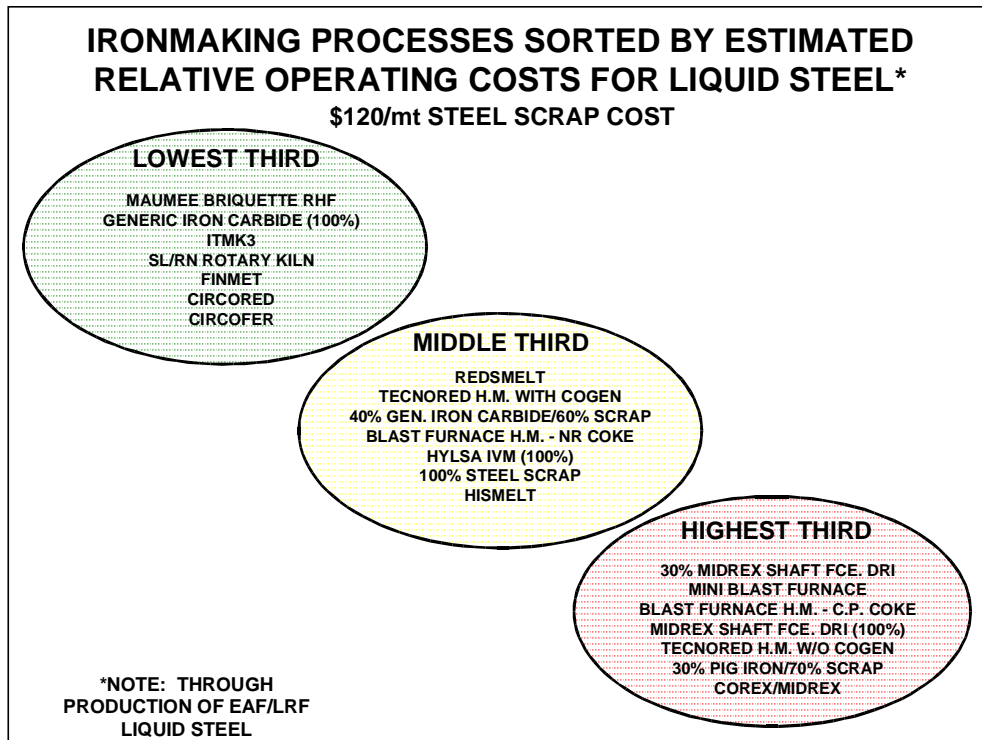
Presented below are the Sorts on Liquid Steel Production Costs for the three sensitivity prices.

**Figure 4-3.1**  
**(Based on \$100/mt Steel Scrap Cost)**



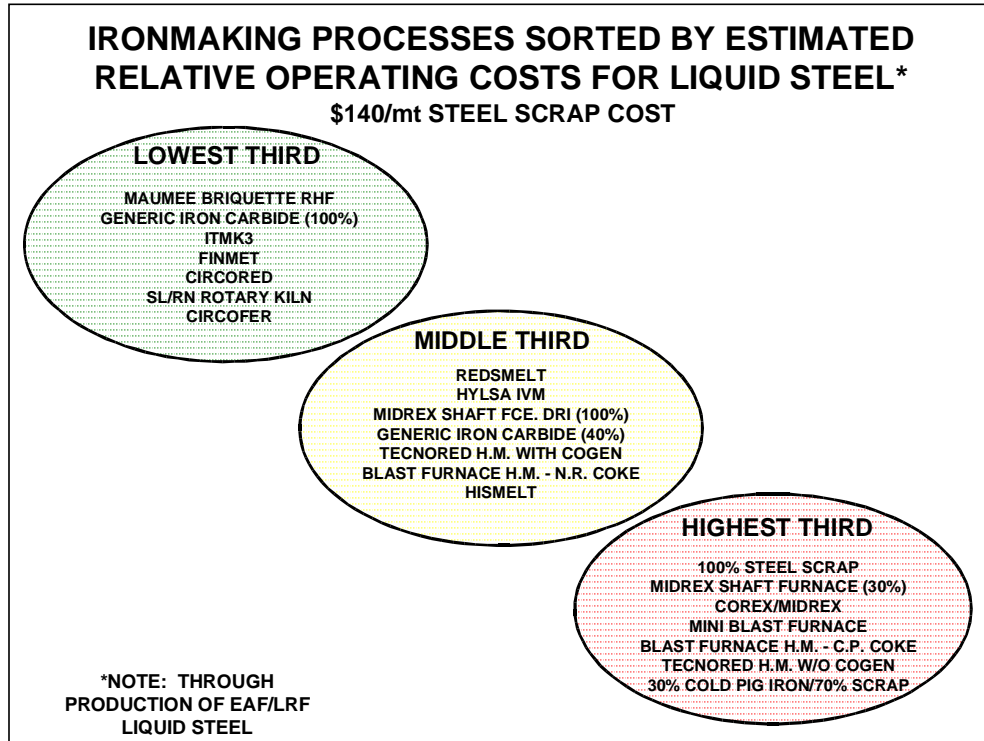
Rev. 06-Aug-00

**Figure 4-3.2**  
**(Based on \$120/mt Steel Scrap Cost)**



Rev. 04-Aug-00

**Figure 4-3.3**  
**(Based on \$140/mt Steel Scrap Cost)**



Rev. 06-Aug-00

**Table 4-3.1**  
**(Based on \$100/mt Steel Scrap Cost)**

**VARIABLES FOR RANKING OF IRONMAKING PROCESSES - SORT ON L.S. OPEX**

<b>RANK</b>	<b>SEQ. NO.</b>	<b>PROCESS</b>	<b>OPEX FOR L.S. (\$/ANN. mt L.S.)</b>
<b>LOWEST THIRD</b>			
1	2	100% STEEL SCRAP	\$176.83
2	14	MAUMEE BRIQUETTE DRI/EAF	\$177.03
3	9	30% TECNORED H.M. W COGEN	\$177.67
4	19	GENERIC IRON CARBIDE (100%)/EAF	\$177.84
5	7	30% BF H.M./70% SCRAP NR COKE	\$178.23
6	15	ITMK3 DR SHOT TO EAF	\$178.76
7	20	GENERIC I.C. (40%)/SAF/EAF*	\$179.90
<b>MIDDLE THIRD</b>			
8	21	SL/RN ROTARY KILN	\$180.74
9	18	FINMET/HBI/EAF	\$185.12
10	16	CIRCORED/HBI/EAF	\$185.27
11	13	REDSMELT	\$188.31
12	17	CIRCOFER/HBI/SAF/EAF	\$188.55
13	3	30% DRI, 1.0% C/70% SCRAP	\$188.64
14	5	30% BF H.M./70% SCRAP CP COKE	\$189.65
<b>HIGHEST THIRD</b>			
15	6	30% MINI-BF H.M.*	\$189.65
16	12	HISMELT 32.7% H.M.	\$190.82
17	10	30% TECNORED H.M. W/O COGEN	\$190.98
18	4	HLYSA IVM	\$196.15
19	8	30% COLD PIG IRON/70% SCRAP	\$198.05
20	1	100% DRI, 1.0% C, MIDREX	\$205.39
21	11	COREX/MIDREX WITH 60% H.M.	\$218.17

**Table 4-3.2**  
**(Based on \$120/mt Steel Scrap Cost)**

**VARIABLES FOR RANKING OF IRONMAKING PROCESSES - SORT ON L.S. OPEX**

<b>RANK</b>	<b>SEQ. NO.</b>	<b>PROCESS</b>	<b>OPEX FOR L.S. (\$/ANN. mt L.S.)</b>
<b>LOWEST THIRD</b>			
1	14	MAUMEE BRIQUETTE DRI/EAF	\$177.03
2	19	GENERIC IRON CARBIDE (100%)/EAF	\$177.84
3	15	ITMK3 DR SHOT TO EAF	\$181.12
4	21	SL/RN ROTARY KILN	\$183.10
5	18	FINMET/HBI/EAF	\$185.12
6	16	CIRCORED/HBI/EAF	\$185.27
7	17	CIRCOFER/HBI/SAF/EAF	\$188.55
<b>MIDDLE THIRD</b>			
8	13	REDSMELT	\$190.67
9	9	30% TECNORED H.M. W COGEN	\$192.41
10	20	GENERIC I.C. (40%)/SAF/EAF	\$192.65
11	7	30% BF H.M./70% SCRAP NR COKE	\$192.97
12	4	HYLSA IVM	\$196.15
13	2	100% STEEL SCRAP	\$197.39
14	12	HISMELT 32.7% H.M.	\$198.19
<b>HIGHEST THIRD</b>			
15	3	30% DRI, 1.0% C/70% SCRAP	\$203.36
16	5	30% BF H.M./70% SCRAP CP COKE	\$204.39
17	6	30% MINI-BF H.M.	\$204.39
18	1	100% DRI, 1.0% C, MIDREX	\$205.39
19	10	30% TECNORED H.M. W/O COGEN	\$205.72
20	8	30% COLD PIG IRON/70% SCRAP	\$212.79
21	11	COREX/MIDREX WITH 60% H.M.	\$218.16

**Table 4-3.3**  
**(Based on \$140/mt Steel Scrap Cost)**

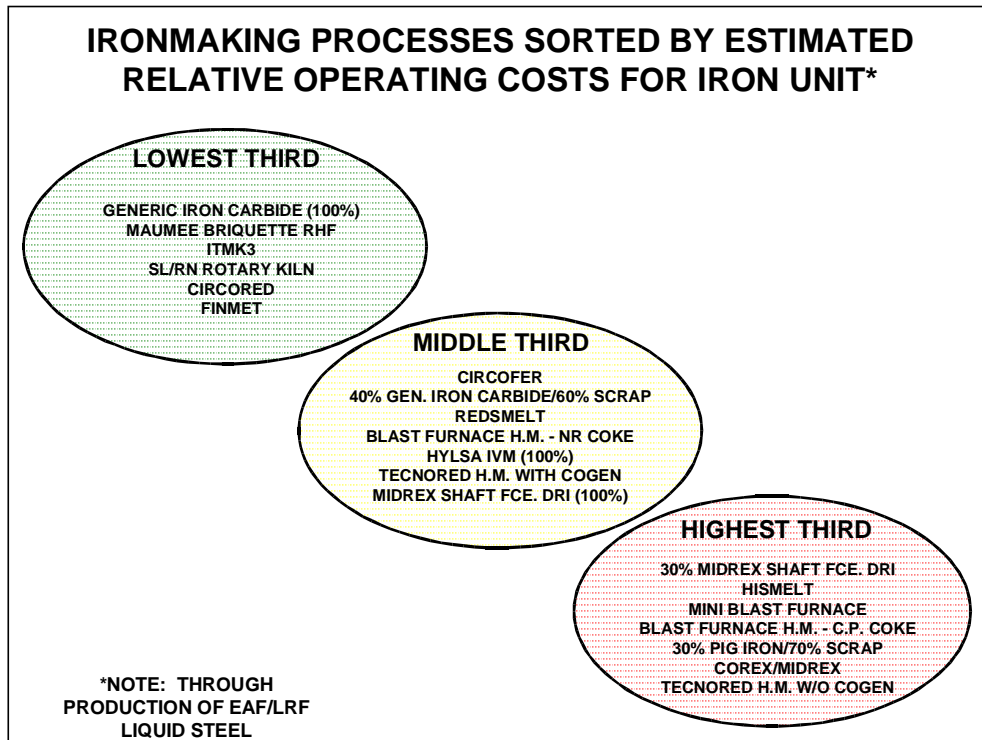
**VARIABLES FOR RANKING OF IRONMAKING PROCESSES - SORT ON L.S. OPEX**

<b>RANK</b>	<b>SEQ. NO.</b>	<b>PROCESS</b>	<b>OPEX FOR L.S. (\$/ANN. mt L.S.)</b>
<b>LOWEST THIRD</b>			
1	14	MAUMEE BRIQUETTE DRI/EAF	\$177.03
2	19	GENERIC IRON CARBIDE (100%)/EAF	\$177.84
3	15	ITMK3 DR SHOT TO EAF	\$183.48
4	18	FINMET/HBI/EAF	\$185.12
5	16	CIRCORED/HBI/EAF	\$185.27
6	21	SL/RN ROTARY KILN	\$185.46
7	17	CIRCOFER/HBI/SAF/EAF	\$188.55
<b>MIDDLE THIRD</b>			
8	13	REDSMELT	\$193.03
9	4	HYLSA IVM	\$196.15
10	1	100% DRI, 1.0% C, MIDREX	\$205.39
11	20	GENERIC I.C. (40%)/SAF/EAF*	\$205.40
12	9	30% TECNORED H.M. W COGEN	\$207.14
13	7	30% BF H.M./70% SCRAP NR COKE	\$207.70
14	12	HISMELT 32.7% H.M.	\$212.92
<b>HIGHEST THIRD</b>			
15	2	100% STEEL SCRAP	\$217.95
16	3	30% DRI, 1.0% C/70% SCRAP	\$218.09
17	11	COREX/MIDREX WITH 60% H.M.	\$218.17
18	6	30% MINI-BF H.M.*	\$219.12
19	5	30% BF H.M./70% SCRAP CP COKE	\$219.12
20	10	30% TECNORED H.M. W/O COGEN	\$220.45
21	8	30% COLD PIG IRON/70% SCRAP	\$227.52

## 4-4:            Sorting and Ranking By Operating Costs Estimates                     Through Iron Unit Production

The Operating Costs for Iron Unit Production do not need to be sensitized on Purchased Steel Scrap Cost. Costs itemized in Tables 2-4.3 through 2-4.5 and provided in detail in Volume II, Appendix F-4 are sorted and ranked below.

Figure 4-4.1



Rev. 04-Aug-00

**Table 4-4.1**

**VARIABLES FOR RANKING OF IRONMAKING PROCESSES - SORT ON I.U. OPEX**

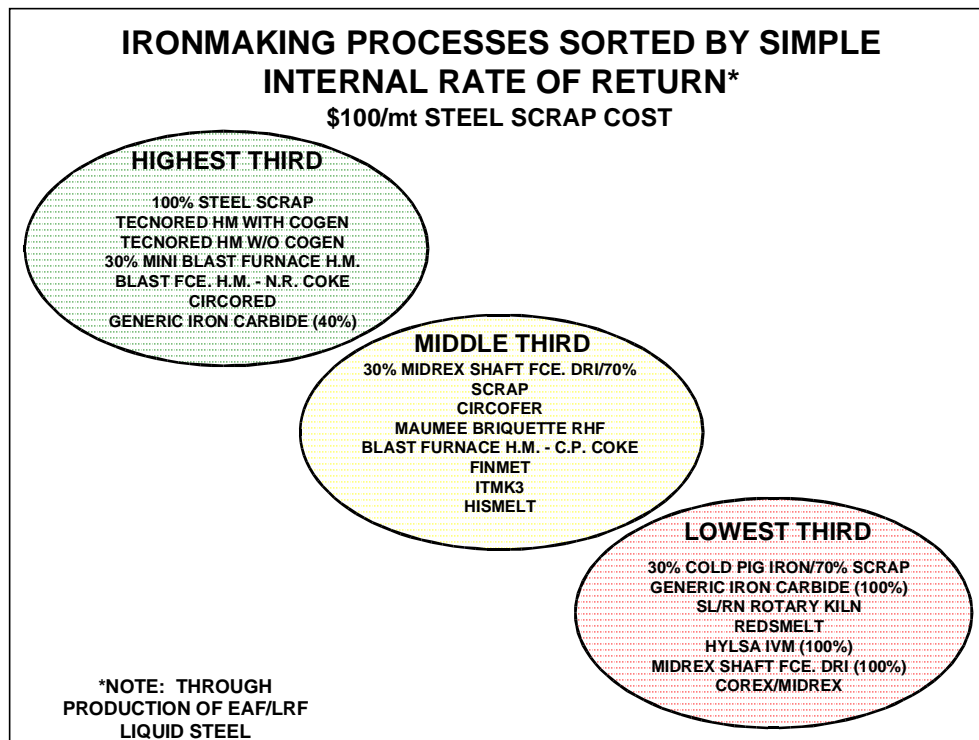
<b>RANK</b>	<b>SEQ. NO.</b>	<b>PROCESS</b>	<b>OPEX FOR I.U. (\$/ANN. mt I.U.)</b>
<b>LOWEST THIRD</b>			
1	2	100% STEEL SCRAP	\$0.00
2	19	GENERIC IRON CARBIDE (100%)/EAF	\$66.19
3	14	MAUMEE BRIQUETTE DRI/EAF	\$66.44
4	15	ITMK3 DR SHOT TO EAF	\$67.60
5	21	SL/RN ROTARY KILN	\$74.08
6	16	CIRCORED/HBI/EAF	\$78.79
7	18	FINMET/HBI/EAF	\$79.42
<b>MIDDLE THIRD</b>			
8	17	CIRCOFER/HBI/SAF/EAF	\$96.20
9	20	GENERIC I.C. (40%)/SAF/EAF	\$100.79
10	13	REDSMELT	\$101.83
11	7	30% BF H.M./70% SCRAP NR COKE	\$110.77
12	4	HYLSA IVM	\$125.52
13	9	30% TECNORED H.M. W COGEN	\$125.95
14	1	100% DRI, 1.0% C, MIDREX	\$132.44
<b>HIGHEST THIRD</b>			
15	3	30% DRI, 1.0% C/70% SCRAP	\$137.51
16	12	HISMELT 32.7% H.M.	\$137.85
17	6	30% MINI-BF H.M.	\$142.86
18	5	30% BF H.M./70% SCRAP CP COKE	\$142.86
19	8	30% COLD PIG IRON/70% SCRAP	\$145.12
20	11	COREX/MIDREX WITH 60% H.M.	\$161.83
21	10	30% TECNORED H.M. W/O COGEN	\$163.09



## 4-5:            Sorting and Ranking By Simple Internal Rate of Return (I.R.R.)

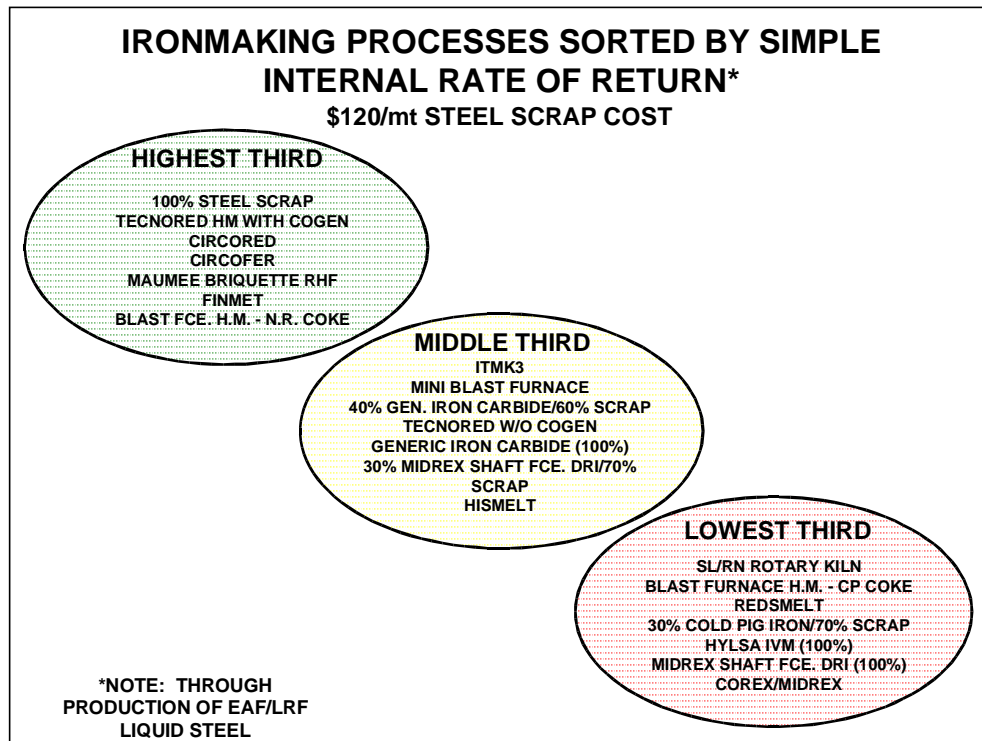
To better compare the impacts of Capital and Operating Costs for each Ironmaking process, a Simple Internal Rate of Return calculation was made for each process. The Standard Methodology followed for this calculation assumed 75% of the Capitalization was spent in Year 1 and 25% spent in Year 2. There was no production in Year 1 and 75% of capacity production in Year 2. A 20-year Project Life was assumed. These values were also sensitized on Purchased Steel Scrap Cost. These I.R.R. calculations for each process are sorted and ranked below.

Figure 4-5.1



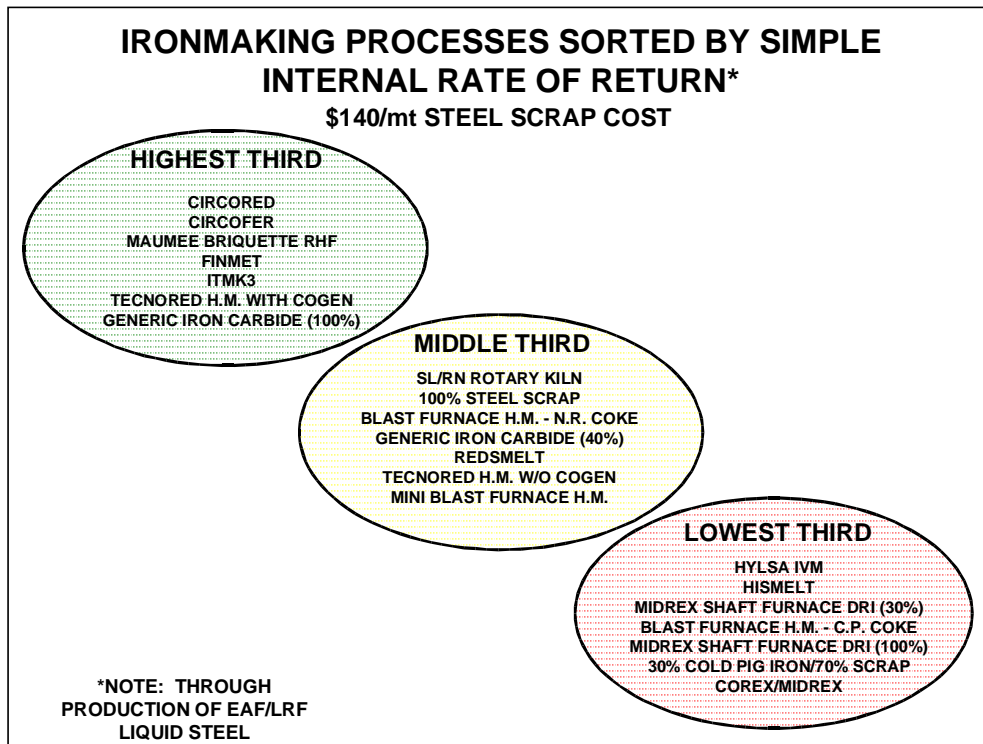
Rev. 06-Aug-00

Figure 4-5.2



Rev. 04-Aug-00

Figure 4-5.3



Rev. 06-Aug-00

**Table 4-5.1**  
**(\$100/mt Scrap Cost Sensitivity)**

**VARIABLES FOR RANKING OF IRONMAKING PROCESSES - SORTED ON I.R.R.**

<b>RANK</b>	<b>SEQ. NO.</b>	<b>PROCESS</b>	<b>INTERNAL RATE OF RETURN</b>
<b>HIGHEST THIRD</b>			
1	2	100% STEEL SCRAP	42.09%
2	9	30% TECNORED H.M. W COGEN	36.74%
3	10	30% TECNORED H.M. W/O COGEN	31.30%
4	6	30% MINI-BF H.M.*	30.32%
5	7	30% BF H.M./70% SCRAP NR COKE	29.28%
6	16	CIRCORED/HBI/EAFF	27.64%
7	20	GENERIC I.C. (40%)/SAF/EAFF*	27.02%
<b>MIDDLE THIRD</b>			
8	3	30% DRI, 1.0% C/70% SCRAP	26.21%
9	17	CIRCOFER/HBI/SAF/EAFF	25.37%
10	14	MAUMEE BRIQUETTE DRI/EAFF	24.66%
11	5	30% BF H.M./70% SCRAP CP COKE	24.46%
12	18	FINMET/HBI/EAFF	24.31%
13	15	ITMK3 DR SHOT TO EAFF	23.72%
14	12	HISMELT 32.7% H.M.	22.39%
<b>LOWEST THIRD</b>			
15	8	30% COLD PIG IRON/70% SCRAP	20.43%
16	19	GENERIC IRON CARBIDE (100%)/EAFF	20.24%
17	21	SL/RN ROTARY KILN	19.55%
18	13	REDSMELT	17.73%
19	4	HYLSA IVM	13.72%
20	1	100% DRI, 1.0% C, MIDREX	10.57%
21	11	COREX/MIDREX WITH 60% H.M.	5.72%

**Table 4-5.2**  
**(\$120/mt Scrap Cost Sensitivity)**

**VARIABLES FOR RANKING OF IRONMAKING PROCESSES - SORT ON I.R.R.**

<b>RANK</b>	<b>SEQ. NO.</b>	<b>PROCESS</b>	<b>INTERNAL RATE OF RETURN</b>
<b>HIGHEST THIRD</b>			
1	2	100% STEEL SCRAP	30.14%
2	9	30% TECNORED H.M. W COGEN	29.14%
3	16	CIRCORED/HBI/EAF	27.64%
4	17	CIRCOFER/HBI/SAF/EAF	25.37%
5	14	MAUMEE BRIQUETTE DRI/EAF	24.66%
6	18	FINMET/HBI/EAF	24.31%
7	7	30% BF H.M./70% SCRAP NR COKE	23.04%
<b>MIDDLE THIRD</b>			
8	15	ITMK3 DR SHOT TO EAF	22.89%
9	6	30% MINI-BF H.M.	22.64%
10	20	GENERIC I.C. (40%)/SAF/EAF	21.87%
11	10	30% TECNORED H.M. W/O COGEN	20.25%
12	19	GENERIC IRON CARBIDE (100%)/EAF	20.24%
13	3	30% DRI, 1.0% C/70% SCRAP	19.55%
14	12	HISMELT 32.7% H.M.	19.38%
<b>LOWEST THIRD</b>			
15	21	SL/RN ROTARY KILN	18.81%
16	5	30% BF H.M./70% SCRAP CP COKE	18.04%
17	13	REDSMELT	16.96%
18	8	30% COLD PIG IRON/70% SCRAP	13.89%
19	4	HYLSA IVM	13.72%
20	1	100% DRI, 1.0% C, MIDREX	10.57%
21	11	COREX/MIDREX WITH 60% H.M.	5.72%

**Table 4-5.3**  
**(\$140/mt Scrap Cost Sensitivity)**

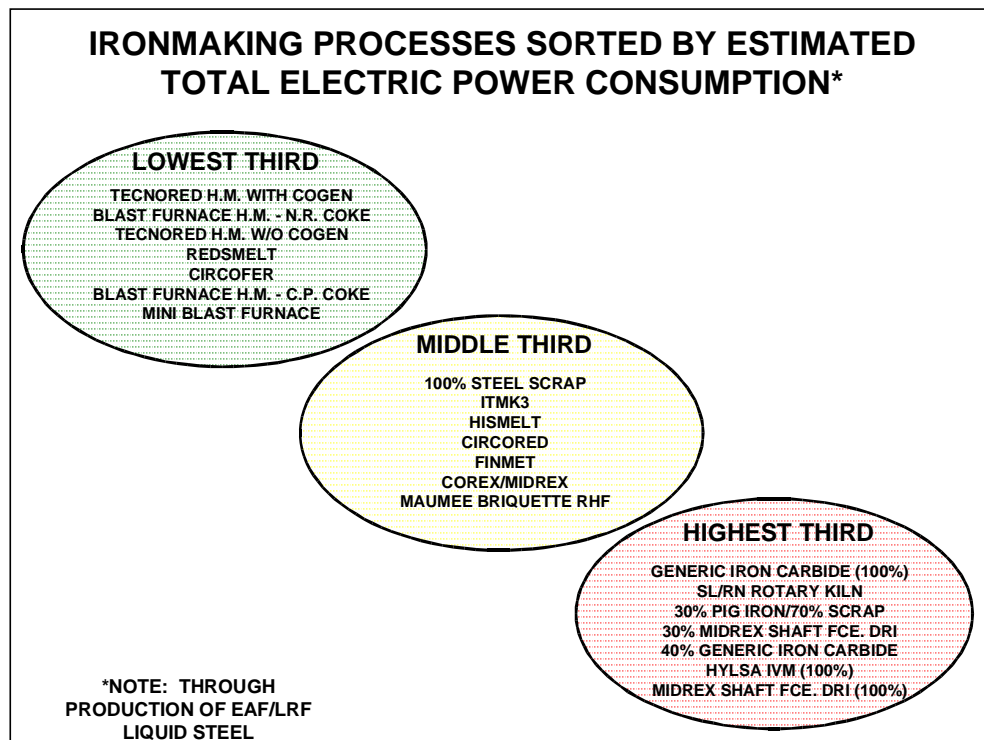
**VARIABLES FOR RANKING OF IRONMAKING PROCESSES - SORTED ON I.R.R.**

<b>RANK</b>	<b>SEQ. NO.</b>	<b>PROCESS</b>	<b>INTERNAL RATE OF RETURN</b>
<b>HIGHEST THIRD</b>			
1	16	CIRCORED/HBI/ EAF	27.64%
2	17	CIRCOFER/HBI/SAF/ EAF	25.37%
3	14	MAUMEE BRIQUETTE DRI/ EAF	24.66%
4	18	FINMET/HBI/ EAF	24.31%
5	15	ITMK3 DR SHOT TO EAF	22.05%
6	9	30% TECNORED H.M. W COGEN	21.36%
7	19	GENERIC IRON CARBIDE (100%)/EAF	20.24%
<b>MIDDLE THIRD</b>			
8	21	SL/RN ROTARY KILN	18.06%
9	2	100% STEEL SCRAP	17.75%
10	7	30% BF H.M./70% SCRAP NR COKE	16.55%
11	20	GENERIC I.C. (40%)/SAF/ EAF*	16.52%
12	13	REDSMELT	16.17%
13	10	30% TECNORED H.M. W/O COGEN	14.74%
14	6	30% MINI-BF H.M.*	14.56%
<b>LOWEST THIRD</b>			
15	4	HYLSA IVM	13.72%
16	12	HISMELT 32.7% H.M.	13.05%
17	3	30% DRI, 1.0% C/70% SCRAP	12.45%
18	5	30% BF H.M./70% SCRAP CP COKE	11.14%
19	1	100% DRI, 1.0% C, MIDREX	10.57%
20	8	30% COLD PIG IRON/70% SCRAP	6.48%
21	11	COREX/MIDREX WITH 60% H.M.	5.72%

## 4-6:            Sorting and Ranking By Total Electric Power Consumptions

An important process variable and one also related to the total greenhouse gas emissions for a process is the Total Cumulative Electrical Power Consumption. This not only includes the Ironmaking and Steelmaking processes, but also all electrical power consumption (on a weighted basis) for all of the components and raw materials feed to the Iron and Steelmaking processes. The breakdown and bases of the electrical power consumptions are provided in the Process Summaries, Volume II, Appendices C and F.

Figure 4-6.1



Rev. 04-Aug-00

**Table 4-6.1**

**VARIABLES FOR RANKING OF IRONMAKING PROCESSES - SORT ON TOTAL ELECTRICITY**

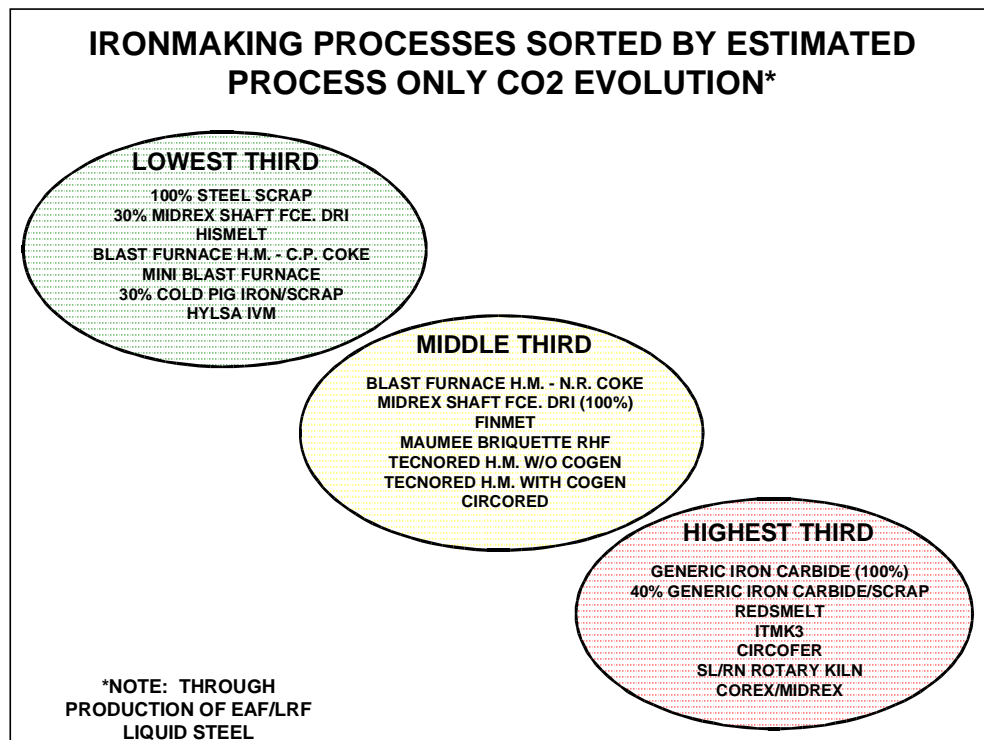
<b>RANK</b>	<b>SEQ. NO.</b>	<b>PROCESS</b>	<b>TOTAL ELEC. (kWhr/mt LS)</b>
<b>LOWEST THIRD</b>			
1	9	30% TECNORED H.M. W COGEN	307.58
2	7	30% BF H.M./70% SCRAP NR COKE	660.35
3	10	30% TECNORED H.M. W/O COGEN	685.69
4	13	REDSMELT	690.28
5	17	CIRCOFER/HBI/SAF/ EAF	780.99
6	5	30% BF H.M./70% SCRAP CP COKE	795.44
7	6	30% MINI-BF H.M.	795.44
<b>MIDDLE THIRD</b>			
8	2	100% STEEL SCRAP	822.45
9	15	ITMK3 DR SHOT TO EAF	825.40
10	12	HISMELT 32.7% H.M.	847.37
11	16	CIRCORED/HBI/EAF	900.84
12	18	FINMET/HBI/EAF	907.76
13	11	COREX/MIDREX WITH 60% H.M.	942.91
14	14	MAUMEE BRIQUETTE DRI/EAF	966.09
<b>HIGHEST THIRD</b>			
15	19	GENERIC IRON CARBIDE (100%)/EAF	972.95
16	21	SL/RN ROTARY KILN	999.74
17	8	30% COLD PIG IRON/70% SCRAP	1,002.39
18	3	30% DRI, 1.0% C/70% SCRAP	1,030.37
19	20	GENERIC I.C. (40%)/SAF/EAF	1,185.22
20	4	HYLSA IVM	1,267.37
21	1	100% DRI, 1.0% C, MIDREX	1,326.73



## 4-7:            **Sorting and Ranking By Cumulative Process Greenhouse Gas (As CO<sub>2</sub> Only) Emissions**

Another important process variable is the total greenhouse gas emissions for the Process. In this Study, this variable was calculated as being the total cumulative carbon gas emissions only (as expresses as CO<sub>2</sub>) for all component, raw material and intermediate processes through the production of LRS in the Ironmaking and Steelmaking processes. These were derived in the detailed mass balances of the processes (Volume II, Appendices C and F).

Figure 4-7.1



Rev. 04-Aug-00

**Table 4-7.1**

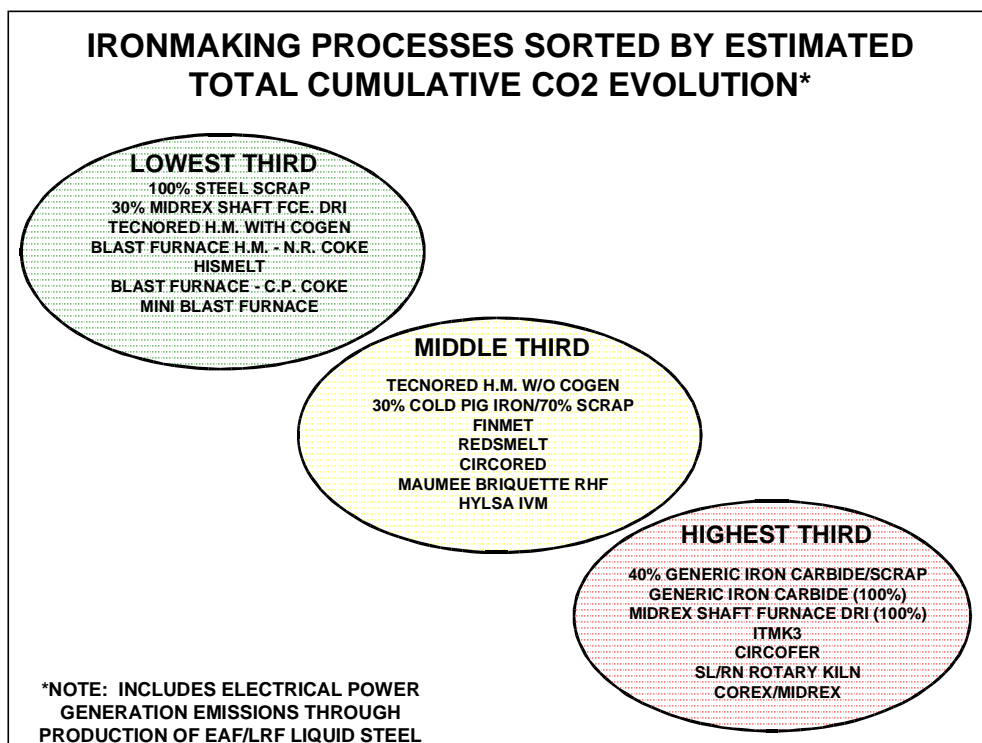
**VARIABLES FOR RANKING OF IRONMAKING PROCESSES - SORT ON PROCESS CO2**

<b>RANK</b>	<b>SEQ. NO.</b>	<b>PROCESS</b>	<b>PROCESS CO2 (mt/mt LS)</b>
<b>LOWEST THIRD</b>			
1	2	100% STEEL SCRAP	0.0874
2	3	30% DRI, 1.0% C/70% SCRAP	0.4283
3	12	HISMELT 32.7% H.M.	0.8689
4	5	30% BF H.M./70% SCRAP CP COKE	0.8974
5	6	30% MINI-BF H.M.	0.8974
6	8	30% COLD PIG IRON/70% SCRAP	0.9027
7	4	HYLSA IVM	0.9086
<b>MIDDLE THIRD</b>			
8	7	30% BF H.M./70% SCRAP NR COKE	0.9594
9	1	100% DRI, 1.0% C, MIDREX	1.0514
10	18	FINMET/HBI/EAF	1.0742
11	14	MAUMEE BRIQUETTE DRI/EAF	1.1498
12	10	30% TECNORED H.M. W/O COGEN	1.1545
13	9	30% TECNORED H.M. W COGEN	1.1545
14	16	CIRCORED/HBI/EAF	1.1999
<b>HIGHEST THIRD</b>			
15	19	GENERIC IRON CARBIDE (100%)/EAF	1.2864
16	20	GENERIC I.C. (40%)/SAF/EAF	1.3320
17	13	REDSMELT	1.3624
18	15	ITMK3 DR SHOT TO EAF	1.5213
19	17	CIRCOFER/HBI/SAF/EAF	1.6404
20	21	SL/RN ROTARY KILN	2.2869
21	11	COREX/MIDREX WITH 60% H.M.	2.9239

**4-8:            Sorting and Ranking By Total Cumulative  
(Including Electrical Power Generation  
Contribution) Greenhouse Gas (As CO<sub>2</sub> Only)  
Emissions**

It should be noted that the contribution to the Total Cumulative Greenhouse Gas Emissions (again expressed as carbon gases as CO<sub>2</sub> only) derived from Electrical Power Generation is Significant. Utilizing the generating and fuel source types for North American averages (Volume II, Appendix B-1), the contribution to the total emissions due to electrical power generation ranges from about the same as the Process up to double that of the Process. Those processes that minimize the electrical power consumption, thus generally result in less total emissions.

**Figure 4-8.1**



Rev. 04-Aug-00

**Table 4-8.1**

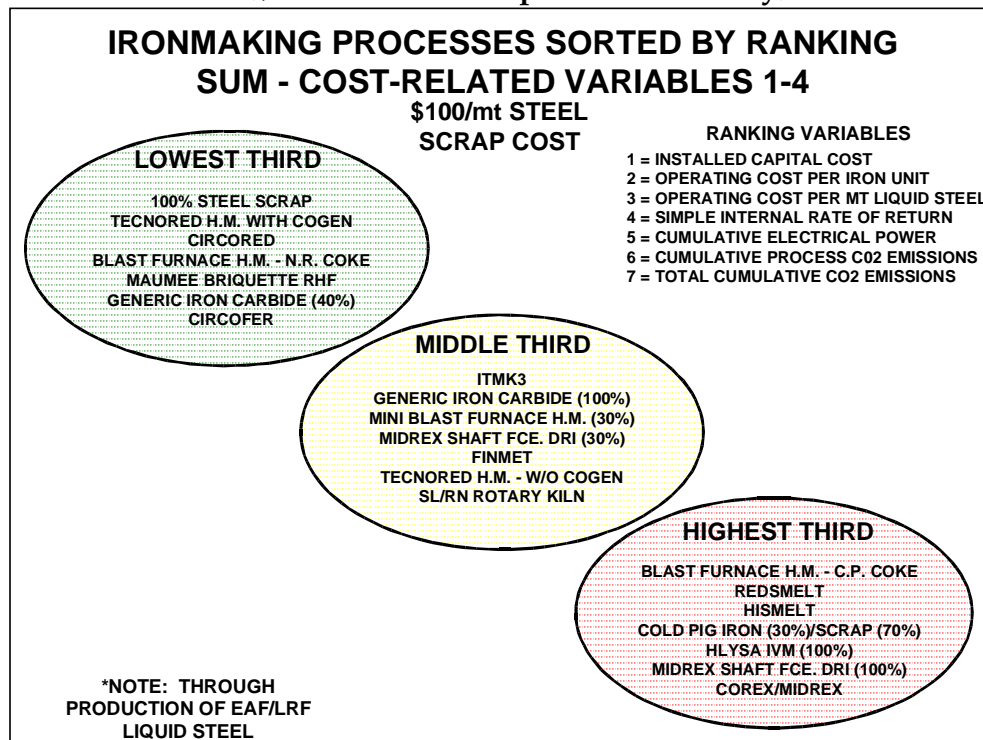
**VARIABLES FOR RANKING OF IRONMAKING PROCESSES - TOTAL CUMULATIVE CO2**

<b>RANK</b>	<b>SEQ. NO.</b>	<b>PROCESS</b>	<b>TOTAL CO2 (mt/mt LS)</b>
<b>LOWEST THIRD</b>			
1	2	100% STEEL SCRAP	0.8909
2	3	30% DRI, 1.0% C/70% SCRAP	1.3681
3	9	30% TECNORED H.M. W COGEN	1.4350
4	7	30% BF H.M./70% SCRAP NR COKE	1.5615
5	12	HISMELT 32.7% H.M.	1.6418
6	5	30% BF H.M./70% SCRAP CP COKE	1.6746
7	6	30% MINI-BF H.M.	1.6746
<b>MIDDLE THIRD</b>			
8	10	30% TECNORED H.M. W/O COGEN	1.7799
9	8	30% COLD PIG IRON/70% SCRAP	1.8170
10	18	FINMET/HBI/EAF	1.9022
11	13	REDSMELT	1.9921
12	16	CIRCORED/HBI/EAF	2.0217
13	14	MAUMEE BRIQUETTE DRI/EAF	2.0310
14	4	HYLSA IVM	2.0646
<b>HIGHEST THIRD</b>			
15	20	GENERIC I.C. (40%)/SAF/EAF	2.0648
16	19	GENERIC IRON CARBIDE (100%)/EAF	2.1738
17	1	100% DRI, 1.0% C, MIDREX	2.2617
18	15	ITMK3 DR SHOT TO EAF	2.2742
19	17	CIRCOFER/HBI/SAF/EAF	2.3528
20	21	SL/RN ROTARY KILN	3.1988
21	11	COREX/MIDREX WITH 60% H.M.	3.7839

## 4-9 Weighted Ranking Summaries

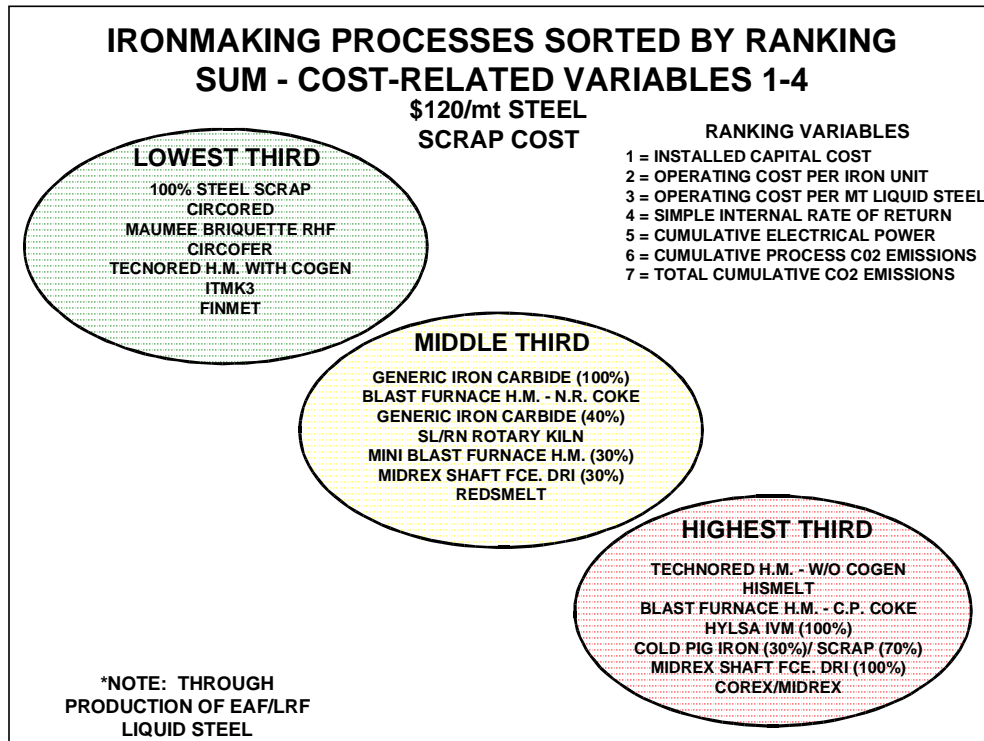
A significant and powerful diagnostic tool for comparing a number of similar scenarios utilizing multiple variables for comparison is the Weighted Ranking Technique. Simply stated, the Ranks (order of the Sorts in Sections 4-2 through 4-8) are arithmetically summed. These summed rankings were also sorted and grouped into the Lower Third, the Middle Third and the Higher Third, thus producing a multi-variable comparison for the Ironmaking processes. In this Study, Variables 1-4 (CAPEX, OPEX for I.U., OPEX for L.S. and I.R.R.) were one Summed Rank reflecting economic variables. Variables 5-7 (Electric Power, Process CO<sub>2</sub> and Total CO<sub>2</sub>) or the Environmental Variables were a second Summed Rank and the Sum of all Variables 1-7 were a third Summed Rank reflecting all variables. It should be noted that the Steel Scrap Cost required a sensitivity on these sums. These tabulations and groupings are summarized below and in more detail in Volume II, Appendix G).

**Figure 4-9.1**  
**(\$100/mt Steel Scrap Cost Sensitivity)**



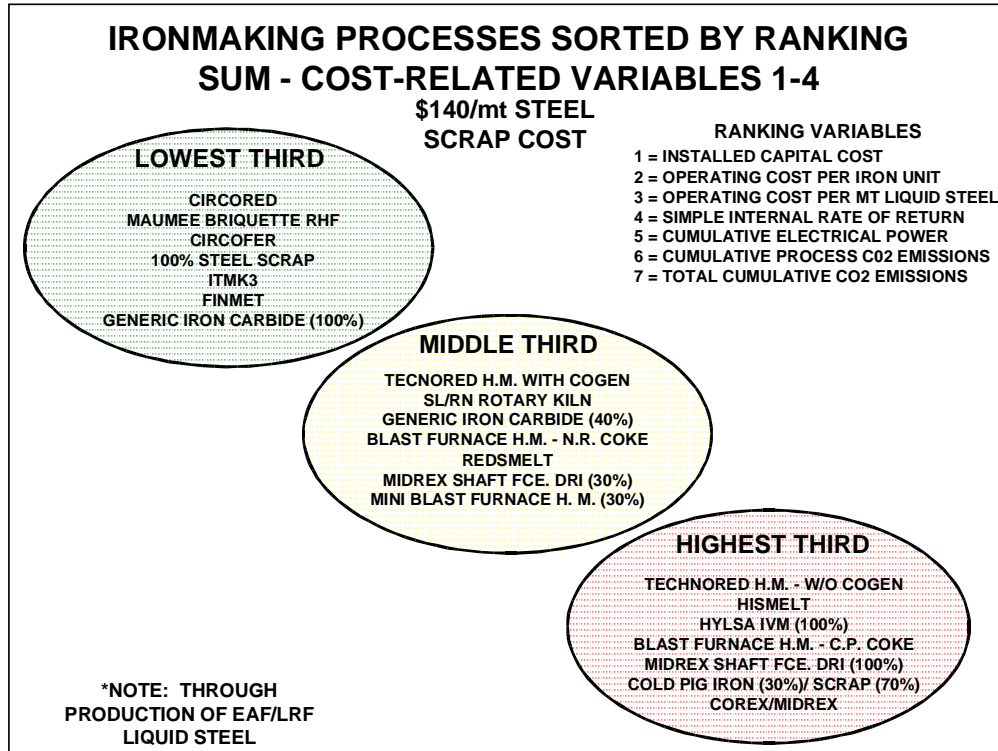
Rev. 07-Aug-00

**Figure 4-9.2**  
**(\$120/mt Steel Scrap Cost Sensitivity)**



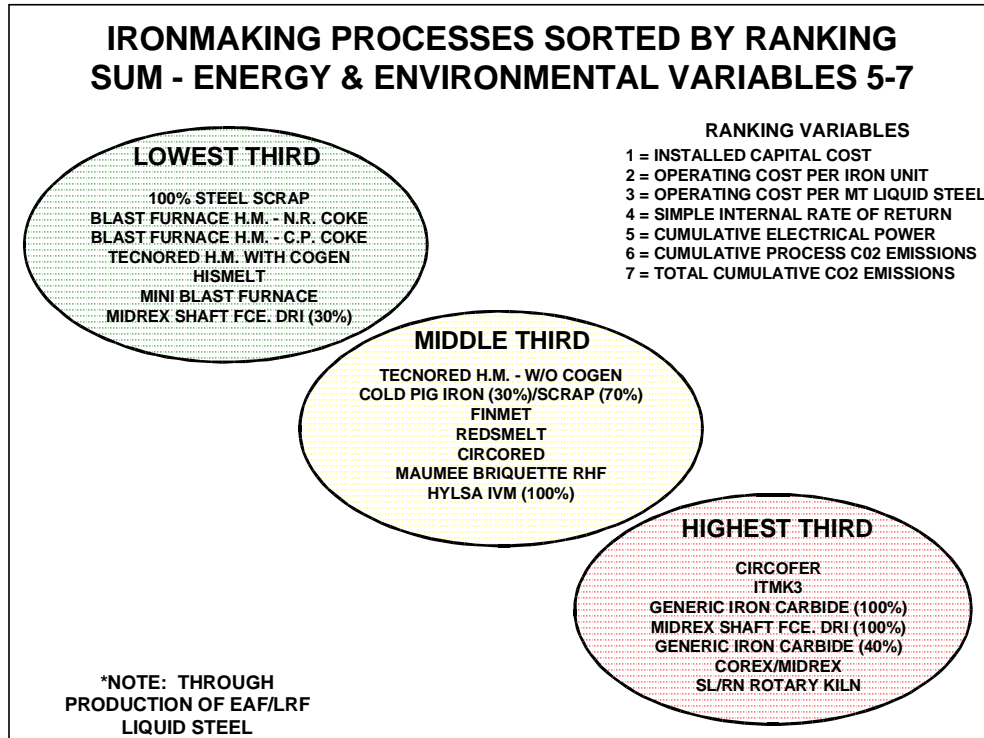
Rev. 07-Aug-00

**Figure 4-9.3**  
**(\$140/mt Steel Scrap Cost Sensitivity)**



Rev. 07-Aug-00

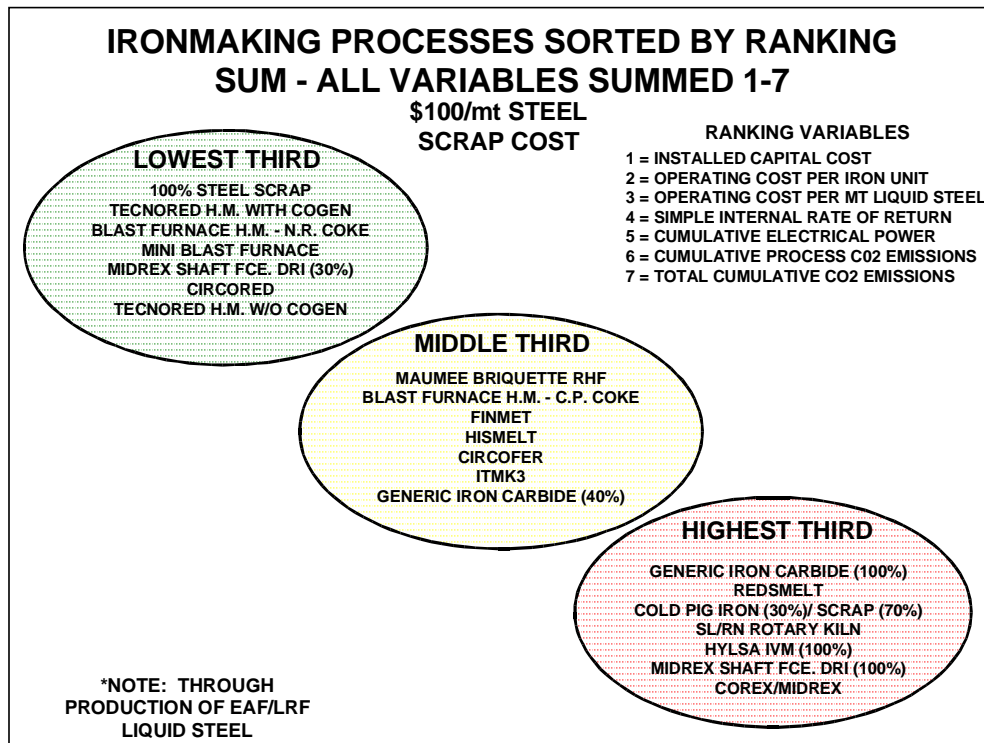
**Figure 4-9.4  
(No Steel Scrap Cost Sensitivity)**



Rev. 07-Aug-00

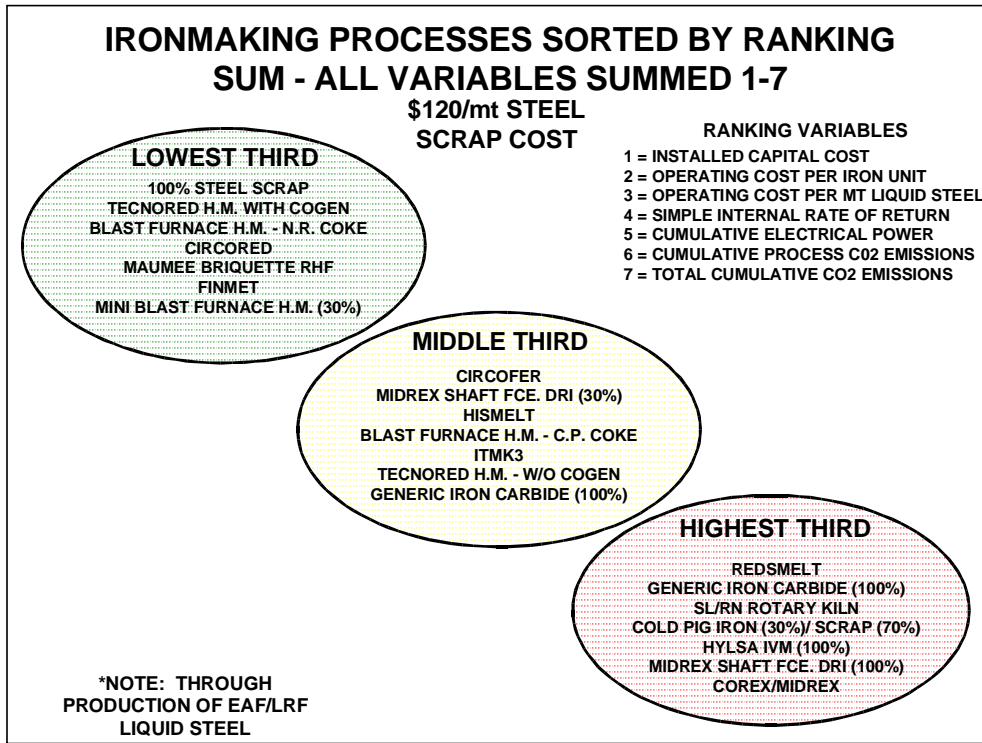


**Figure 4-9.5**  
**(\$100/mt Steel Scrap Cost Sensitivity)**



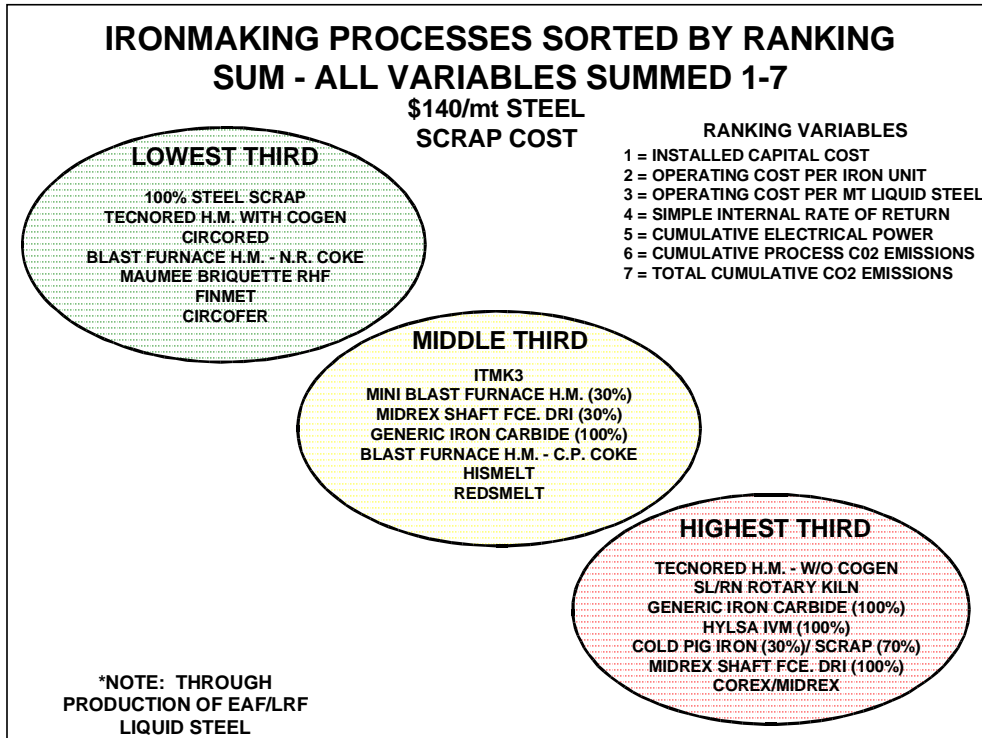
Rev. 07-Aug-00

**Figure 4-9.6**  
**(\$120/mt Steel Scrap Cost Sensitivity)**



Rev. 07-Aug-00

**Figure 4-9.7**  
**(\$140/mt Steel Scrap Cost Sensitivity)**



Rev. 07-Aug-00

**Table 4-9.8: RANKING OF IRONMAKING PROCESSES - RESEQUENCED ORDER**

(BASIS: 1.00 MM mt LIQUID STEEL PER YEAR, \$120/mt STEEL SCRAP COST)

SEQ. NO.	PROCESS	CAPEX RANKING (1)	OPEX I.U. RANKING (2)	OPEX L.S. RANKING (3)	I.R.R. RANKING (4)	ELEC. RANKING (5)	PROC. CO2 RANKING (6)	TOTAL CO2 RANKING (7)	TOTALS (1-4)	TOTALS (1-7)	TOTALS (5-7)	T.S.RANK (1-4)	T.S.RANK (1-7)	T.S.RANK (5-7)
1	100% DRI, 1.0% C, MIDREX	20	14	18	20	21	9	17	72	119	47	20	20	
2	100% STEEL SCRAP	1	1	13	1	8	1	1	16	26	10	1	1	
3	30% DRI, 1.0% C/70% SCRAP	5	15	15	13	18	2	2	48	70	22	13	9	
4	HYLSA IVM	19	12	12	19	20	7	14	62	103	41	18	19	
5	30% BF H.M./70% SCRAP CP COKE	9	18	16	16	6	4	6	59	75	16	17	11	
6	30% MINI-BF H.M.	4	17	17	9	7	5	7	47	66	19	12	7	
7	30% BF H.M./70% SCRAP NR COKE	8	11	11	7	2	8	4	37	51	14	9	3	
8	30% COLD PIG IRON/70% SCRAP	10	19	20	18	17	6	9	67	99	32	19	18	
9	30% TECNORED H.M. W COGEN	3	13	9	2	1	13	3	27	44	17	5	2	
10	30% TECNORED H.M. W/O COGEN	2	21	19	11	3	12	8	53	76	23	15	13	
11	COREX/MIDREX WITH 60% H.M.	21	20	21	21	13	21	21	83	138	55	21	21	
12	HISMELT 32.7% H.M.	12	16	14	14	10	3	5	56	74	18	16	10	
13	REDSMELT	16	10	8	17	4	17	11	51	83	32	14	15	
14	MAUMEE BRIQUETTE DRI/EAF	14	3	1	5	14	11	13	23	61	38	3	5	
15	ITMK3 DR SHOT TO EAF	15	4	3	8	9	18	18	30	75	45	6	12	
16	CIRCORED/HBI/EAF	6	6	6	3	11	14	12	21	58	37	2	4	
17	CIRCOFER/HBI/SAF/EAF	7	8	7	4	5	19	19	26	69	43	4	8	
18	FINMET/HBI/EAF	13	7	5	6	12	10	10	31	63	32	7	6	
19	GENERIC IRON CARBIDE (100%)/EAF	18	2	2	12	15	15	16	34	80	46	8	14	
20	GENERIC I.C. (40%)/SAF/EAF	11	9	10	10	19	16	15	40	90	50	10	16	
21	SL/RN ROTARY KILN	17	5	4	15	16	20	20	41	97	56	11	17	

**Table 4-9.9: RANKING OF IRONMAKING PROCESSES - SORTED ON RANKING SUM (1-7)**

**BASIS: 1.00 MM mt LIQUID STEEL PER YEAR, \$120/mt STEEL SCRAP COST)**

SEQ. NO.	PROCESS	CAPEX RANKING (1)	OPEX I.U. RANKING (2)	OPEX L.S. RANKING (3)	I.R.R. RANKING (4)	ELEC. RANKING (5)	PROC. CO2 RANKING (6)	TOTAL CO2 RANKING (7)	TOTALS (1-4)	TOTALS (1-7)	TOTALS (5-7)	T.S.RANK (1-4)	T.S.RANK (1-7)	T.S.RANK (5-7)
<b>LOWEST THIRD</b>														
2	100% STEEL SCRAP	1	1	13	1	8	1	1	16	26	10	1	1	
9	30% TECNORED H.M. W COGEN	3	13	9	2	1	13	3	27	44	17	5	2	
7	30% BF H.M./70% SCRAP NR COKE	8	11	11	7	2	8	4	37	51	14	9	3	
16	CIRCORED/HBI/ EAF	6	6	6	3	11	14	12	21	58	37	2	4	
14	MAUMEE BRIQUETTE DRI/EAF	14	3	1	5	14	11	13	23	61	38	3	5	
18	FINMET/HBI/EAF	13	7	5	6	12	10	10	31	63	32	7	6	
6	30% MINI-BF H.M.	4	17	17	9	7	5	7	47	66	19	12	7	
<b>MIDDLE THIRD</b>														
17	CIRCOFER/HBI/SAF/EAF	7	8	7	4	5	19	19	26	69	43	4	8	
3	30% DRI, 1.0% C/70% SCRAP	5	15	15	13	18	2	2	48	70	22	13	9	
12	HISMELT 32.7% H.M.	12	16	14	14	10	3	5	56	74	18	16	10	
5	30% BF H.M./70% SCRAP CP COKE	9	18	16	16	6	4	6	59	75	16	17	11	
15	ITMK3 DR SHOT TO EAF	15	4	3	8	9	18	18	30	75	45	6	12	
10	30% TECNORED H.M. W/O COGEN	2	21	19	11	3	12	8	53	76	23	15	13	
19	GENERIC IRON CARBIDE (100%)/EAF	18	2	2	12	15	15	16	34	80	46	8	14	
<b>HIGHEST THIRD</b>														
13	REDSMELT	16	10	8	17	4	17	11	51	83	32	14	15	
20	GENERIC I.C. (40%)/SAF/EAF	11	9	10	10	19	16	15	40	90	50	10	16	
21	SL/RN ROTARY KILN	17	5	4	15	16	20	20	41	97	56	11	17	
8	30% COLD PIG IRON/70% SCRAP	10	19	20	18	17	6	9	67	99	32	19	18	
4	HYLSA IVM	19	12	12	19	20	7	14	62	103	41	18	19	
1	100% DRI, 1.0% C, MIDREX	20	14	18	20	21	9	17	72	119	47	20	20	
11	COREX/MIDREX WITH 60% H.M.	21	20	21	21	13	21	21	83	138	55	21	21	

**Table 4-9.10: RANKING OF IRONMAKING PROCESSES - SORTED ON RANKING SUM (1-4)**

(BASIS: 1.00 MM mt LIQUID STEEL PER YEAR, \$120/mt STEEL SCRAP COST)

SEQ. NO.	PROCESS	CAPEX RANKING (1)	OPEX I.U. RANKING (2)	OPEX L.S. RANKING (3)	I.R.R. RANKING (4)	ELEC. RANKING (5)	PROC. CO2 RANKING (6)	TOTAL CO2 RANKING (7)	TOTALS (1-4)	TOTALS (1-7)	TOTALS (5-7)	T.S.RANK (1-4)	T.S.RANK (1-7)	T.S.RANK (5-7)
<b>LOWEST THIRD</b>														
2	100% STEEL SCRAP	1	1	13	1	8	1	1	16	26	10	1	1	
16	CIRCORED/HBI/ EAF	6	6	6	3	11	14	12	21	58	37	2	4	
14	MAUMEE BRIQUETTE DRI/ EAF	14	3	1	5	14	11	13	23	61	38	3	5	
17	CIRCOFER/HBI/SAF/ EAF	7	8	7	4	5	19	19	26	69	43	4	8	
9	30% TECNORED H.M. W COGEN	3	13	9	2	1	13	3	27	44	17	5	2	
15	ITMK3 DR SHOT TO EAF	15	4	3	8	9	18	18	30	75	45	6	12	
18	FINMET/HBI/ EAF	13	7	5	6	12	10	10	31	63	32	7	6	
<b>MIDDLE THIRD</b>														
19	GENERIC IRON CARBIDE (100%)/EAF	18	2	2	12	15	15	16	34	80	46	8	14	
7	30% BF H.M./70% SCRAP NR COKE	8	11	11	7	2	8	4	37	51	14	9	3	
20	GENERIC I.C. (40%)/SAF/ EAF	11	9	10	10	19	16	15	40	90	50	10	16	
21	SL/RN ROTARY KILN	17	5	4	15	16	20	20	41	97	56	11	17	
6	30% MINI-BF H.M.	4	17	17	9	7	5	7	47	66	19	12	7	
3	30% DRI, 1.0% C/70% SCRAP	5	15	15	13	18	2	2	48	70	22	13	9	
13	REDSMELT	16	10	8	17	4	17	11	51	83	32	14	15	
<b>HIGHEST THIRD</b>														
10	30% TECNORED H.M. W/O COGEN	2	21	19	11	3	12	8	53	76	23	15	13	
12	HISMELT 32.7% H.M.	12	16	14	14	10	3	5	56	74	18	16	10	
5	30% BF H.M./70% SCRAP CP COKE	9	18	16	16	6	4	6	59	75	16	17	11	
4	HYLSA IVM	19	12	12	19	20	7	14	62	103	41	18	19	
8	30% COLD PIG IRON/70% SCRAP	10	19	20	18	17	6	9	67	99	32	19	18	
1	100% DRI, 1.0% C, MIDREX	20	14	18	20	21	9	17	72	119	47	20	20	
11	COREX/MIDREX WITH 60% H.M.	21	20	21	21	13	21	21	83	138	55	21	21	

**Table 4-9.11: RANKING OF IRONMAKING PROCESSES - SORTED ON RANKING SUM (5-7)**

(BASIS: 1.00 MM mt LIQUID STEEL PER YEAR, \$120/mt STEEL SCRAP COST)

SEQ. NO.	PROCESS	CAPEX RANKING (1)	OPEX I.U. RANKING (2)	OPEX L.S. RANKING (3)	I.R.R. RANKING (4)	ELEC. RANKING (5)	PROC. CO2 RANKING (6)	TOTAL CO2 RANKING (7)	TOTALS (1-4)	TOTALS (1-7)	TOTALS (5-7)	T.S.RANK (1-4)	T.S.RANK (1-7)	T.S.RANK (5-7)
<b>LOWEST THIRD</b>														
2	100% STEEL SCRAP	1	1	13	1	8	1	1	16	26	10	1	1	
7	30% BF H.M./70% SCRAP NR COKE	8	11	11	7	2	8	4	37	51	14	9	3	
5	30% BF H.M./70% SCRAP CP COKE	9	18	16	16	6	4	6	59	75	16	17	11	
9	30% TECNORED H.M. W/ COGEN	3	13	9	2	1	13	3	27	44	17	5	2	
12	HISMELT 32.7% H.M.	12	16	14	14	10	3	5	56	74	18	16	10	
6	30% MINI-BF H.M.	4	17	17	9	7	5	7	47	66	19	12	7	
3	30% DRI, 1.0% C/70% SCRAP	5	15	15	13	18	2	2	48	70	22	13	9	
<b>MIDDLE THIRD</b>														
10	30% TECNORED H.M. W/O COGEN	2	21	19	11	3	12	8	53	76	23	15	13	
8	30% COLD PIG IRON/70% SCRAP	10	19	20	18	17	6	9	67	99	32	19	18	
18	FINMET/HBI/EAFF	13	7	5	6	12	10	10	31	63	32	7	6	
13	REDSMELT	16	10	8	17	4	17	11	51	83	32	14	15	
16	CIRCORED/HBI/EAFF	6	6	6	3	11	14	12	21	58	37	2	4	
14	MAUMEE BRIQUETTE DRI/EAFF	14	3	1	5	14	11	13	23	61	38	3	5	
4	HYLSA IVM	19	12	12	19	20	7	14	62	103	41	18	19	
<b>HIGHEST THIRD</b>														
17	CIRCOFER/HBI/SAF/EAFF	7	8	7	4	5	19	19	26	69	43	4	8	
15	ITMK3 DR SHOT TO EAF	15	4	3	8	9	18	18	30	75	45	6	12	
19	GENERIC IRON CARBIDE (100%)/EAF	18	2	2	12	15	15	16	34	80	46	8	14	
1	100% DRI, 1.0% C, MIDREX	20	14	18	20	21	9	17	72	119	47	20	20	
20	GENERIC I.C. (40%)/SAF/EAFF	11	9	10	10	19	16	15	40	90	50	10	16	
11	COREX/MIDREX WITH 60% H.M.	21	20	21	21	13	21	21	83	138	55	21	21	
21	SL/RN ROTARY KILN	17	5	4	15	16	20	20	41	97	56	11	17	

---

## Section 5: Summary and Conclusions

### **5-1: Conclusions From Sorts**

A number of conclusions can be drawn from examination of the grouping of the sorted variables developed in this Study. It can be concluded that those Ironmaking processes (i.e., Process Scenario through EAF/LRF production of LRS) that consistently ended up in the lowest (or most desirable) grouping, would have more desired economics or more favorable environmental impacts than those processes that consistently were grouped in the Middle or Highest groupings.

In the Resequenced Selected Process Scenarios (as ordered in Table 4-9.8) there are 21 selected processes. Thus these were grouped into groups of 7 for purposes of comparison. The discussions below focus processes with common attributes that favor their ranking in the sorted groupings. In addition, attention is called to any specific attribute of a process that moves it into a more favorable or less favorable grouping.

In this subjective analysis of the key variables developed for each process scenario, a consensus on those processes or process attributes that show a favorable potential will be developed.



---

**5-1.1:**            Sorting on Capital Cost Estimates

Summarizing the presentation of sorting results from Section 4-2, the Lowest Grouping of Relative Capital Costs (through EAF/LRF production of LRS) is highlighted.

**Figure 5-1.1**



Conclusions from this lowest grouping of Capital Costs include:

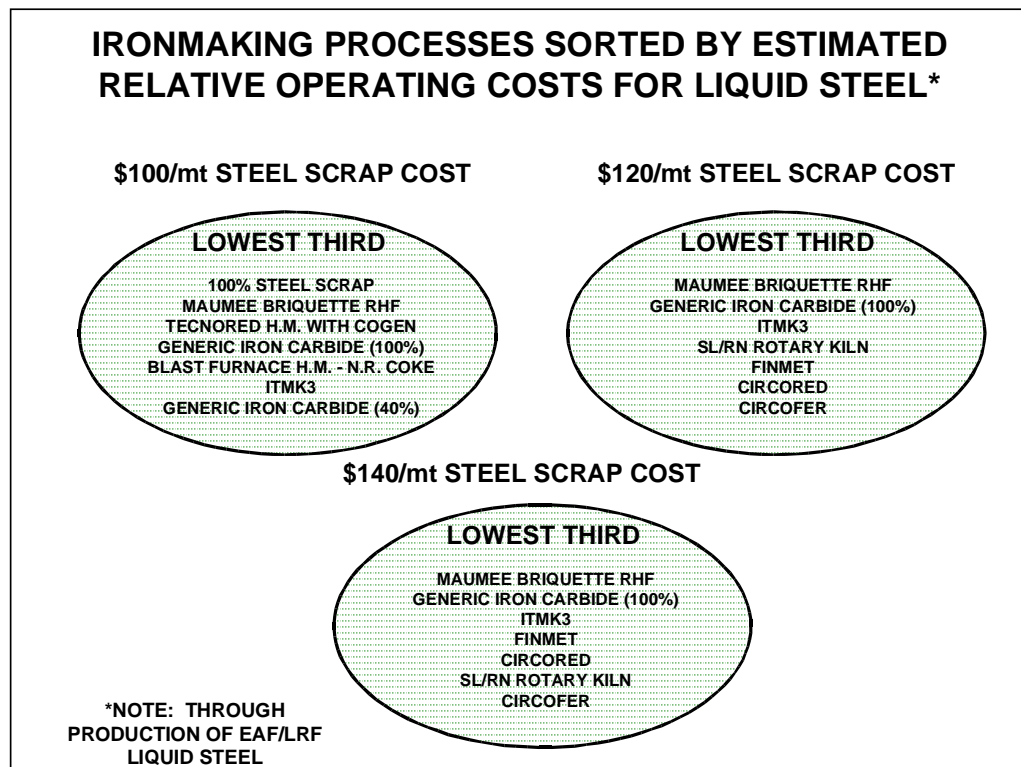
- Processes with fine ore feed (Tecnoled with or without Co-generation, Circored, and Circofer)
- Mini Blast Furnace Process
- Mixture of 30% Midrex DRI/70% Steel Scrap
- Of course the lowest-cost, 100% Steel Scrap charge to the EAF

The weighting of the low-capital cost EAF process results in inclusion of the 30% Midrex Shaft Furnace DRI/70% Steel Scrap case. It should be noted that the similar scenarios with partial Steel Scrap charge also are in the Middle Grouping of Capital Costs.

5-1.2:            Sorting on Operating Costs For Liquid Steel Production

Summarizing the presentation of sorting results from Section 4-3, the Lowest Grouping of Relative Operating Costs (through EAF/LRF production of LRS) is highlighted for the various sensitivity cases for Steel Scrap Cost.

Figure 5-1.2



Rev. 06-Aug-00

Conclusions from these lowest groupings of L.S. Operating Costs include:

- The lowest L.S. Operating Cost processes are highly dependent on Steel Scrap Prices
- Typically for all scrap cost sensitivities:
  - Processes with fine ore feed (Tecnored with Co-generation, Circored, and Circofer) and Blast Furnace with non-recovery coke @ \$100/mt scrap.

- 
- Fine ore feed processes (MauMee, Iron Carbide, ITMK3, Finmet, Circored, and Circofer) and SL/RN @ \$120/mt and \$140/mt scrap costs.
  - These include the lower-cost Rotary Hearth as well as the Fluidized-Bed process.

Except at the lowest scrap price with the low-cost Hot Metal producers (i.e., Tecnored or Blast Furnace both with co-generation), the lowest cost processes are those with low-cost iron ore fines as the primary iron unit feed.

#### 5-1.3:           Sorting on Operating Costs For Iron Unit Production

Summarizing the presentation of sorting results from Section 4-4, the Lowest Grouping of Relative Operating Costs for Iron Unit production is highlighted.

Figure 5-1.3



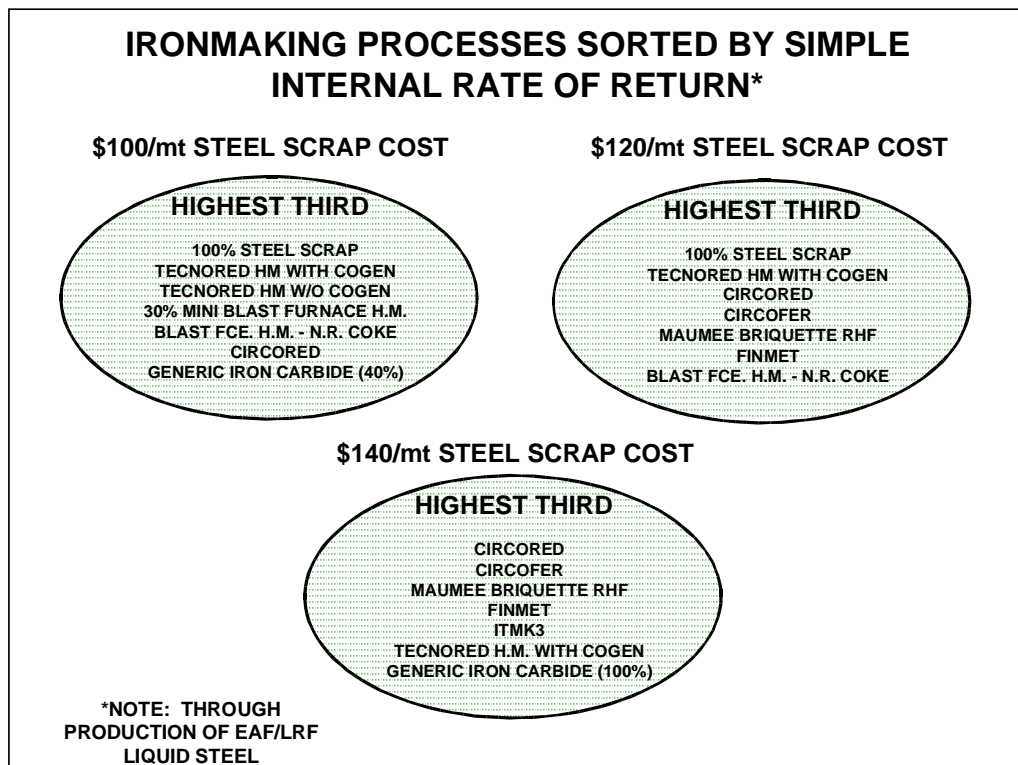
Conclusions from the lowest grouping of Iron Unit Operating Costs include:

- The lowest Iron Unit Operating Cost processes are the fine ore feed processes with Fluidized Beds (Iron Carbide, Circored, Finmet).
- The Rotary Hearth processes (MauMee, ITMK3) with fine ore feed and coal reductant.
- The Rotary Kiln (SL/RN) with coal reductant and low electrical power consumption.

**5-1.4: Sorting on Simple Internal Rate of Return (I.R.R.)**

Summarizing the presentation of sorting results from Section 4-5, the highest Groupings of Simple Internal Rate of Return are highlighted below.

**Figure 5-1.4**



Rev. 06-Aug-00

---

It should be noted that although the Simple Internal Rate of Return calculation is an approximation of a Project's value, this valuable combination of the both the economic factors of Capital Costs and Operating Costs provide a powerful method of comparing the different Ironmaking Scenarios. It should also be noted that there will be a significant sensitivity to the variable of Liquid Steel value, particularly in an absolute comparison. In the relative comparison, it is not so important. In this analysis, a relatively-low value for the Refined Liquid Steel (RLS) of \$250/mt was used to minimize any potential for biasing.

Conclusions from these Highest (i.e., best) groupings of I.R.R. for all scrap cost sensitivities include:

- The highest I.R.R. included 100% Steel Scrap charge to the EAF for \$100 and \$120/mt steel scrap, but did not include 100% Steel Scrap at the \$140/mt sort.
- At the high cost of Steel Scrap (i.e. \$140/mt), the fine ore (fluidized bed, MauMee RHF and the Tecnored H.M. with co-generation) processes were in the most favored (highest I.R.R) group.
- At the lowest cost for Steel Scrap (i.e., \$100/mt), the efficient Hot Metal processes (Tecnored with and without co-generation, the Conventional Blast Furnace with Non-Recovery Coke, and the Mini Blast Furnace) were included.
- In addition, at \$100/mt Scrap, the fluidized bed processes with fine ore (Circored and Iron Carbide) were included.
- At the median Scrap Cost (\$120/mt) the lower-cost MauMee Rotary Hearth process and the fine ore fluidized bed (Circored, Circofer, and Finmet) were included.

The primary conclusions from above indicate that the lower-cost fine ore, the energy efficient Hot Metal processes and those processes with electrical power co-generation (thus reducing operating costs) have the highest economic potential as reflected by the Simple I.R.R. calculation.

---

**5-1.5:           Sorting on Total Electrical Power Consumption**

Summarizing the presentation of sorting results from Section 4-6, the Lowest Grouping of Total Electrical Power Consumption is highlighted below.

**Figure 5-1.5**



Conclusions from this lowest grouping of Total Electrical Power Consumption include:

- The lowest Electrical Power Consumption processes are the hot metal-producing processes (with lower EAF net power) of TecnoRed and Conventional Blast Furnaces (with or without co-generation) and the Mini Blast Furnace.
- The Rotary Hearth process (Redsmelt) and the Fluid-Bed process with fine ore feed and coal reductant (Circofer) also rank in the lowest grouping for power consumption.

The significant common denominator here is that **all of these processes use coal (or a coal derivative) as the primary reductant.**

---

**5-1.6:**            Sorting on Cumulative Process (only) Greenhouse Gas (as CO<sub>2</sub>) Emissions

Summarizing the presentation of sorting results from Section 4-7, the Lowest Grouping of Total Cumulative Process Greenhouse Gas Emissions is highlighted below.

**Figure 5-1.6**



Conclusions from this lowest grouping of Total Cumulative Process Emissions include:

- The 100% Steel Scrap EAF.
- The Hot Metal-producing process of Conventional Blast Furnace with conventional Co-Product Coke (without combustion co-generation), B.F. Pig Iron and the Mini Blast Furnace are in the lower emissions group.
- The Shaft Furnace DRI processes (Midrex and HYLSA IVM) are in the lowest group likely by virtue of the low emissions from the natural gas fired shaft furnace direct reduction processes.
- The Hismelt Oxygen Reactor process also ranked in the Lowest Group for Process Emissions.

Note: This does not include the electrical power component that would influence total emissions.

---

**5-1.7:**        Sorting on Total Cumulative Greenhouse Gas (as CO<sub>2</sub>) Emissions (Including Electrical Power Generation Contribution)

Summarizing the presentation of sorting results from Section 4-8, the Lowest Grouping of Total Cumulative Process Greenhouse Gas Emissions is highlighted below.

Figure 5-1.7



Conclusions from this lowest grouping of Total Cumulative Process Emissions include:

- The 100% Steel Scrap EAF
- The hot metal-producing process of Conventional Blast Furnace with conventional Co-Product Coke and with Non-Recovery Coke and the Mini Blast Furnace are in the lower total emissions group
- Tecnored with co-generation (also a hot metal process)
- The Shaft Furnace DRI process (Midrex)
- The Hismelt Oxygen Reactor process also ranked in the Lowest Group for Total Emissions

Note: This does include the electrical power component that influenced total emissions.



---

## 5-2: Conclusions From Ranking Sorts

The Relative Process Variables utilized for the Ranking Sort Analysis were:

1. CAPEX
2. OPEX for Iron Unit
3. OPEX for Liquid Steel
4. Simple Internal Rate of Return
5. Total Cumulative Electrical Power
6. Total Cumulative Process (Only) Emissions
7. Total Cumulative Emissions (Process and Equivalent E.P. Emissions)

The Ranking Sort Analysis, or regrouping the processes on the sums of their numeric variable sort sequences (from Section 4), was done for all Scrap Cost sensitivities of \$100/mt, \$120/mt and \$140/mt where appropriate. The sums of the sort sequences for variables 1-4 reflect economic considerations, the sums of variables 5-7 reflect energy and environmental considerations and the sums of all of the variables 1-7 present an overall picture of the process scenarios.

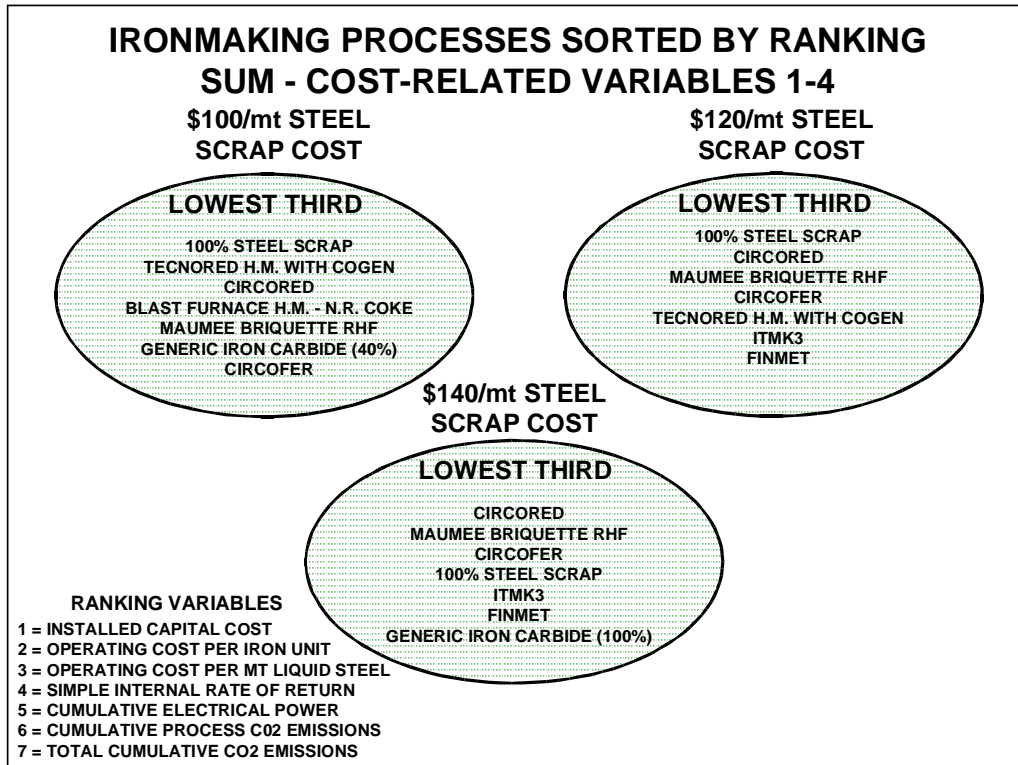
### 5-2.1: Ranking Sort on Economic Variables (1-4)

Referring to the Table 4-9.10 and Volume II, Appendix G, for the Sort and Grouping on the Ranking sums of Economic-Related Variables 1-4, the following groupings are obtained:

- **Lower Grouping:** Most desirable or favorable processes
- **Middle Grouping:** Intermediate desirability
- **Highest Grouping:** Least desirable or favorable processes

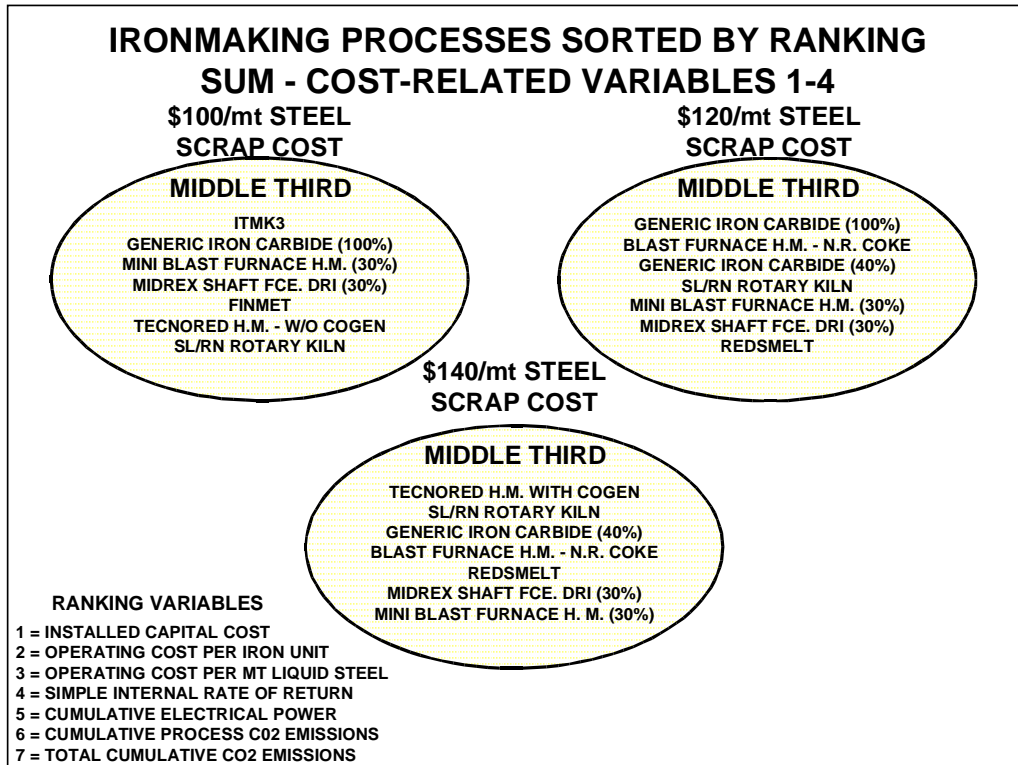
These results are presented in pictorial form in Figures 5-2.1 through 5-2.3.

**Figure 5-2.1**  
**Lowest Group of Sort Rank Sums (1-4)**



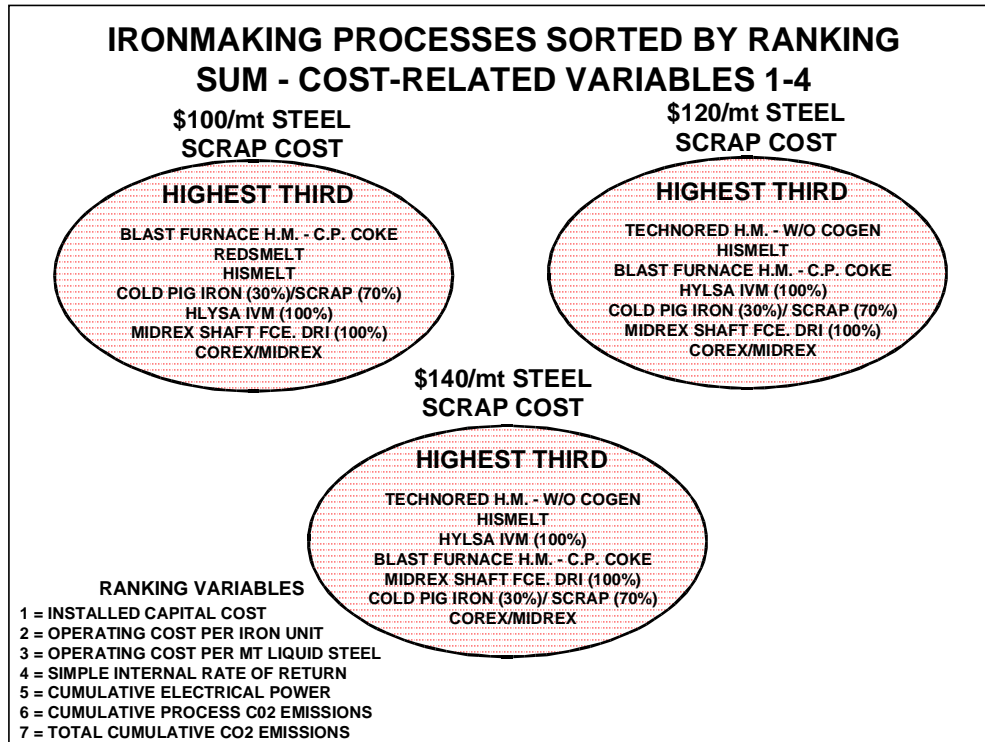
Rev. 14-Aug-00

**Figure 5-2.2  
Middle Group of Sort Rank Sums (1-4)**



Rev. 14-Aug-00

**Figure 5-2.3  
Highest Group of Sort Rank Sums (1-4)**



Rev. 14-Aug-00

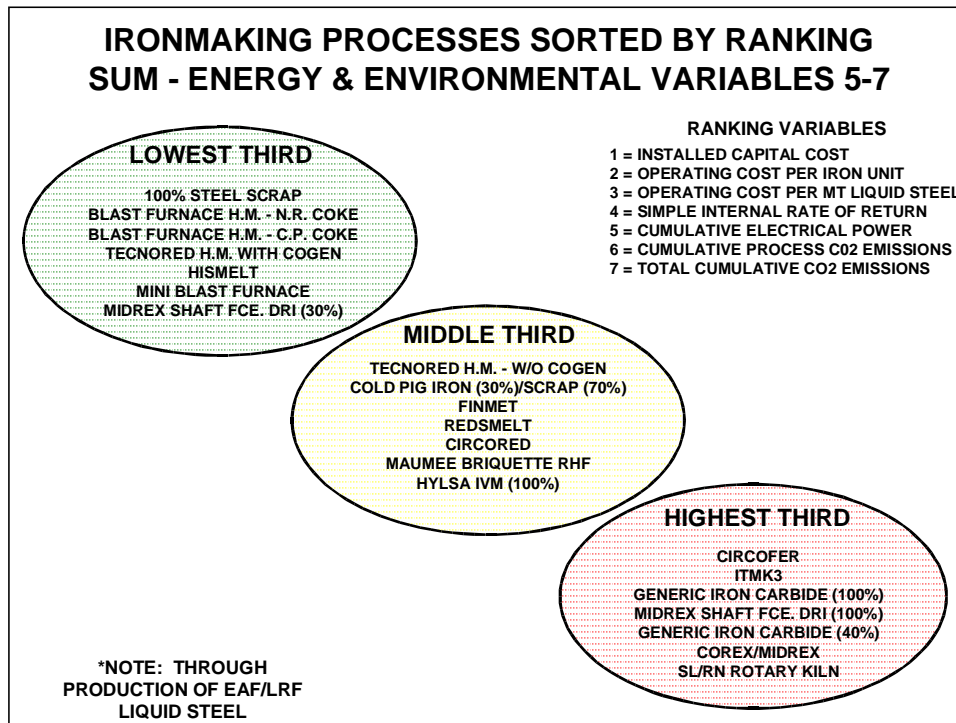
**5-2.2: Ranking Sort on Energy and Environmental Variables (5-7)**

Referring to the Table 4-9.11 and Volume II, Appendix G, for the Sort and Grouping on the Ranking sums of Energy and Environmental Related Variables 5-7, the following groupings are obtained:

- **Lower Grouping:** Most desirable or favorable processes
- **Middle Grouping:** Intermediate desirability
- **Highest Grouping:** Least desirable or favorable processes

These results are presented in pictorial form in Figure 5-2.4 for all Groupings.

**Figure 5-2.4  
All Groups of Sort Rank Sums (5-7)**



Rev. 07-Aug-00

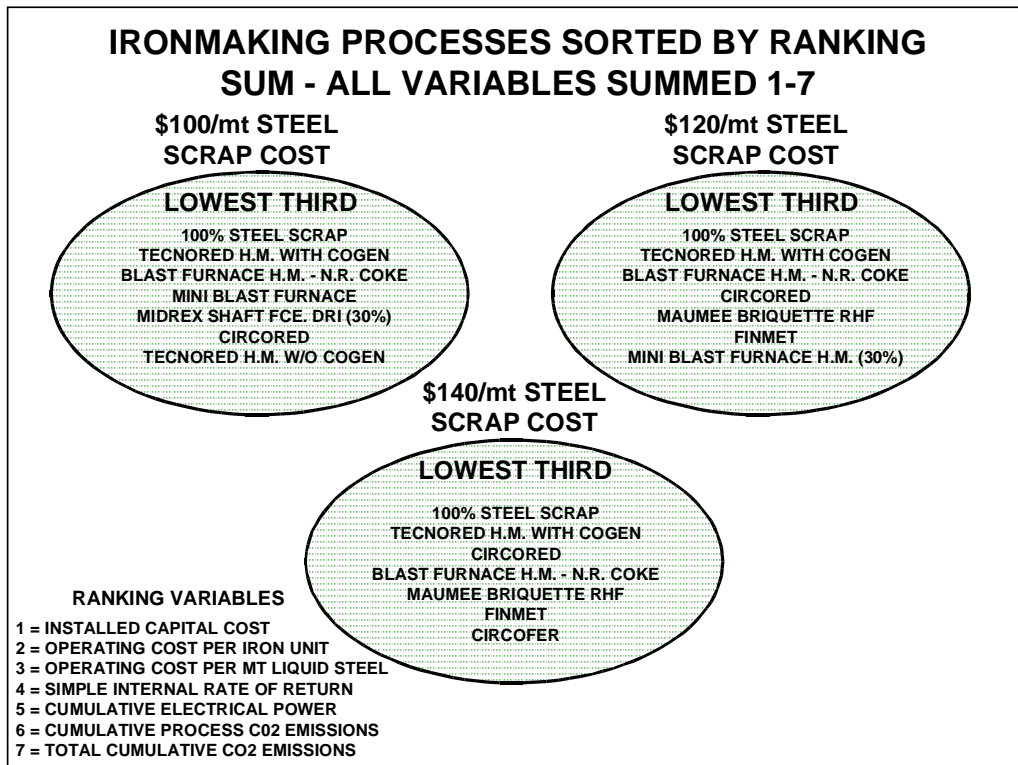
### 5-2.3: Ranking Sort on All Variables (1-7)

Referring to the Table 4-9.9 and Volume II, Appendix G, for the Sort and Grouping on the Ranking sums of All Variables 1-7, the following groupings are obtained:

- **Lower Grouping:** Most desirable or favorable processes
- **Middle Grouping:** Intermediate desirability
- **Highest Grouping:** Least desirable or favorable processes

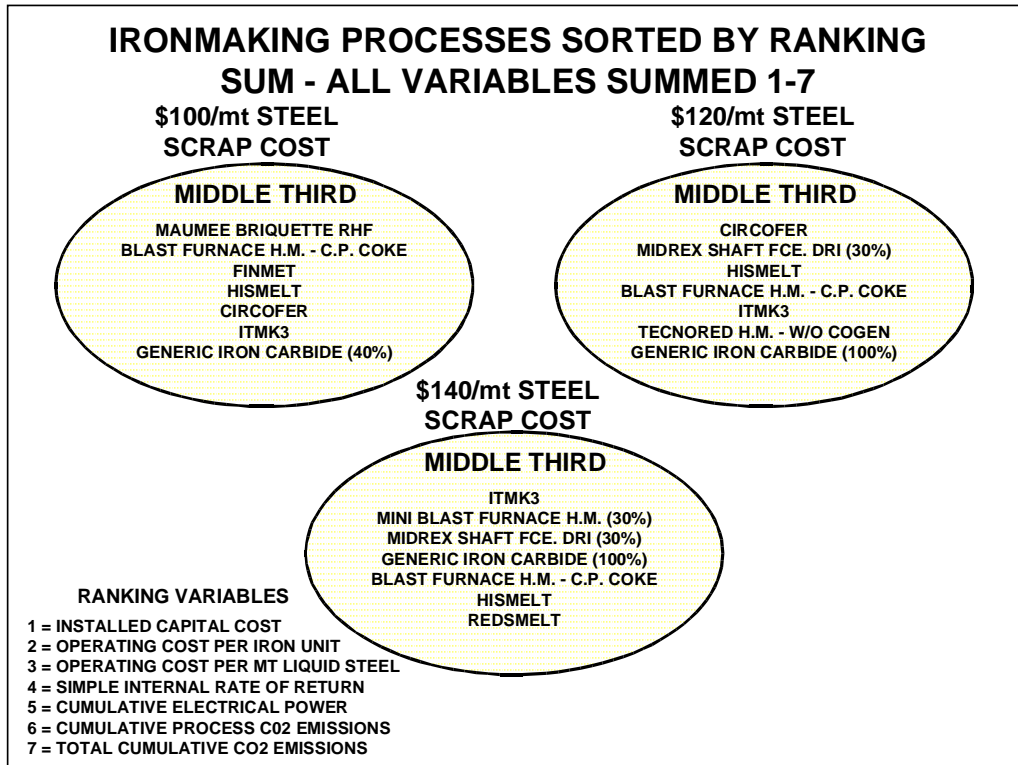
These results are presented in pictorial form in Figures 5-2.5 through 5-2.7 for all Groupings.

**Figure 5-2.5  
Lowest Group of Sort Rank Sums (1-7)**



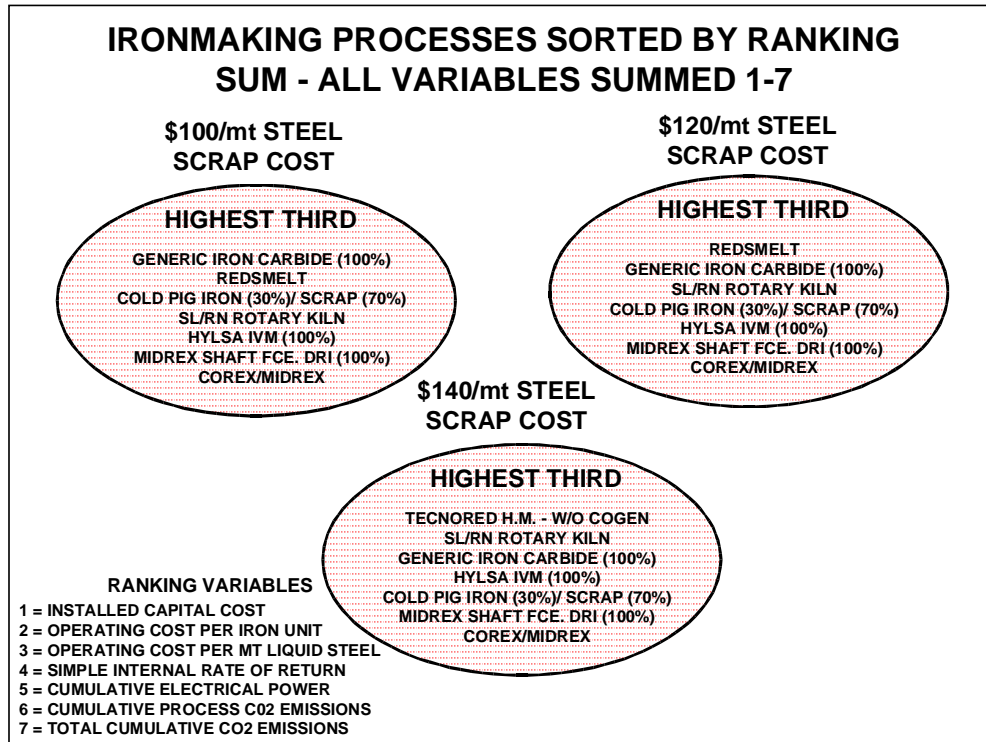
Rev. 14-Aug-00

**Figure 5-2.6**  
**Middle Group of Sort Rank Sums (1-7)**



Rev. 14-Aug-00

**Figure 5-2.7  
Highest Group of Sort Rank Sums (1-7)**



Rev. 14-Aug-00



---

### 5-3: General Conclusions From Sorting and Rank Sums

It should be noted that the following overall conclusions can be made from the sorted, grouped and ranked sum variables reflecting the Ironmaking process scenarios:

- The processes with the best combined economics (CAPEX and OPEX impacts in the I.R.R. calculation) can be grouped into those Fine Ore based processes with no scrap charge and those producing Hot Metal for charge to the EAF.
- A pronounced sensitivity to Steel Scrap Cost was felt less by the Hot Metal Processes and the Fine Ore Processes.
- In terms of evolving processes, the Tecnored Process (and in particular, the lower-operating cost process with integral co-generation of electrical power) was in the most favorable groupings at all scrap cost sensitivities.
- It should be noted also that the Conventional Blast Furnace process utilizing Non-Recovery coke (from a continuous coking process with integral co-generation of electrical power) also showed favorable Relative Economics for the low and median Scrap Cost sensitivities.
- The lower-cost, more efficient MauMee briquetted feed Rotary Hearth Process under initial commercialization also was grouped in the most favorable groups (for median and high scrap cost sensitivities).

Those processes with lower-cost raw materials (i.e., fine ore and/or non-metallurgical coal as the reductant) had favorable combined economics. In addition, the hot metal processes (in part due to the sensible heat impacts in the EAF and due to their inherently lower costs) also had favorable combined economics.

As a group, the processes with the Hot Metal processes had lower Total Cumulative Electrical Power Consumption, lower Process Emissions, and lower Total Emissions (including Electrical Power generation). These were reflected also in the Ranking Sums. The exception was the Shaft Furnace DRI process (Midrex) that was in the lower group for the environmental variables.